

Vman

*Driven by technology.
Built to endure.*

DIESEL

PRODUCT CATALOG

Presented by VMAN Engine, where power meets precision.

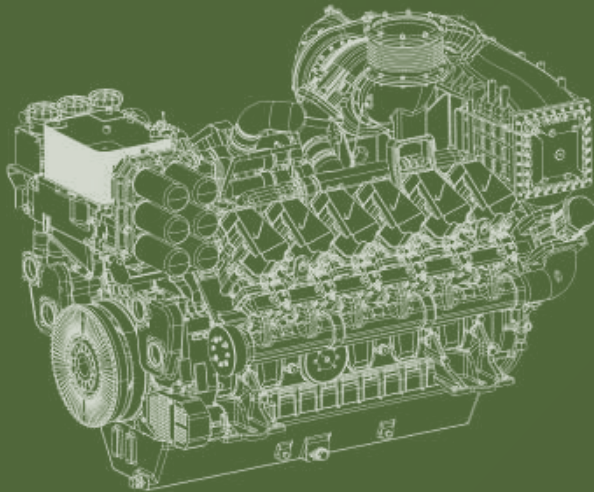

Year **2025**
09th Edition

ABOUT VMAN ENGINE



Vman VMAN is a highly professional engine manufacturing enterprise based in Shanghai, integrating design, research and development, production, and sales into one cohesive operation. Founded in 2007, the company initially imported high-power diesel engine technology. Through continuous overseas study and the localization of parts assembly (CKD) for imported machines (CBU), VMAN has built a skilled and cohesive team.

The company consistently develops new products, adopts advanced manufacturing technologies, utilizes sophisticated production equipment, and leverages extensive production management experience and modern testing methods to establish the VMAN brand as a benchmark of excellence. Every product is strictly controlled across all stages, including

design, procurement, technology, field operations, and quality, ensuring compliance with both domestic and international standards.

VMAN's product portfolio spans from construction machinery, generator sets, marine applications, and more, covering both diesel and gas engines. The power range extends from 25 kW to 2020 kW, with future plans to expand up to 3700 kW. All engines meet Stage II and Stage III emission standards.

Headquartered in Shanghai, VMAN operates a manufacturing facility in Changzhou, China. Additionally, the company has a branch in Singapore and is planning to establish a European branch in the near future.

The **VMAN Engine** boasts a fully advanced manufacturing process and a robust quality management system. Equipped with state-of-the-art facilities and extensive experience in modern production management, we maintain a rigorous approach to part assembly and debugging to prevent leaks of gas, water, and oil. Every engine undergoes a standardized leak test to ensure the highest tightening quality. Additionally, we utilize ESTIC technology (Japanese Nut Runner Machines) for all critical bolts. Each engine is thoroughly debugged and tested before being released to the market.

Utilization of Advanced Technology

All testing equipment is imported from renowned engine manufacturers. Every engine must meet stringent technical standards during on-site trials.

Multi-Level Testing and 110% Load Testing

Each engine undergoes multi-level testing tailored to customer requirements. Additionally, it is subjected to 110% load testing, as well as sudden loading and unloading tests, to ensure the highest quality and reliability.

ISO 9001:2015 Certified Quality Management System

Our production line incorporates advanced methods, including automated delivery systems, rotary carriers, cylinder press fitting, and front-rear oil seal press fitting, to ensure precise control over production and quality.

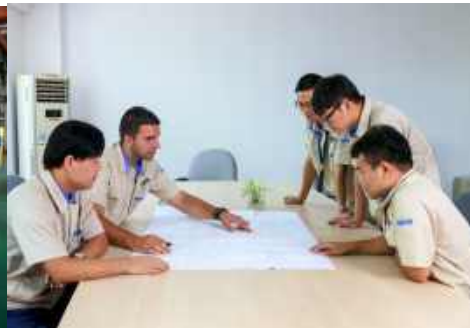

History

2007-2009

- ▶ **Importing technology & Drawing interpretation**
Part drawing, assemble drawing, machine drawing, QA system, etc
- ▶ **Learning & Training**
5 times staff training abroad
4 times professors to our factory for guidance

2009-2014

- ▶ **CKD & CBU Diesel engines**
Getting aptitude of assembling CKD diesel engine, Match up CBU&CKD diesel engines with Customers
- ▶ **Build new factory in Shanghai**
Realize home manufacture and finish all series of V6 V8 V12 V16 engine and get excellent feedback from customers

From 2017

- ▶ **Starting international trading business**
Now had export to Korea, Taiwan, Indonesia, Algeria, Nigeria, Pakistan, Malaysia, UAE, Vietnam, Poland, Albania, Argentina and other countries.

From 2019

- ▶ **Building New Branch factory**
In ChangZhou City, Extend more power range products In particular high power engines up to 2MW.

2020-2022

- ▶ **New C & CE series Engines Launch**
Develop New C&CE series Engines and put to the market. Extend full power range from 62kW to 1100kW

From 2022

- ▶ **Set up branch in Singapore**
VMAN Engine Singapore P, Ltd set up on July.2022.. Provide technical training and service support for the global market.

From 2023

- ▶ **Further expand the product range**
C03 series diesel engine put on the market, power range 25kW to 55kW; CET13 AND DT30 gas engine put on the market, power range 250kW to 500kW.

From 2024

- ▶ **Improvement and new product**
Launch of DE58 and DT58 series engine. Expanding power range to 2222 kW for diesel engines, and 1350kW for gas engines.



New branch factory in ChangZhou City

Table Of Content

Diesel Engine Power Range - kW

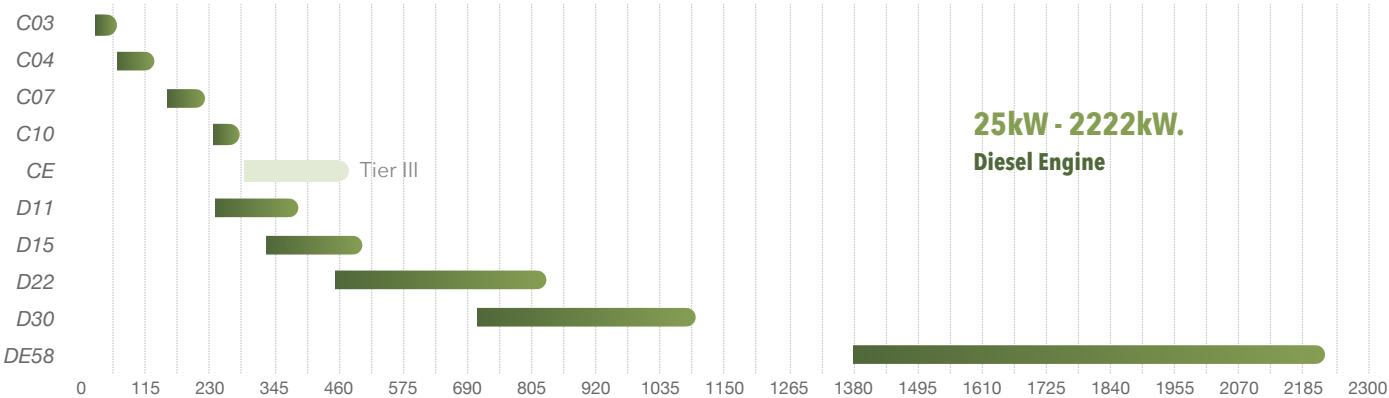

Marine Engine Power Range - Hp

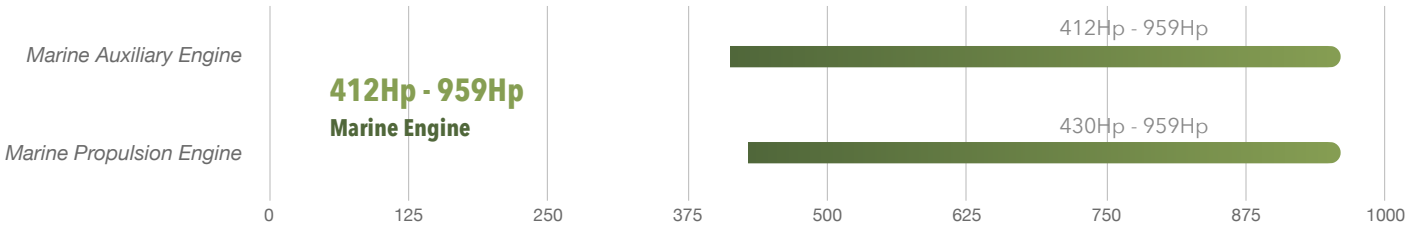

#05

C Series Engine

25kW - 283kW

New P types added to C04 and C07

#18

CE Series Engine

295kW - 275kW

Compatible with Tier III emission standards

#28

D Series Engine

240kW - 2222kW

Newly launched DE58 with power range form 1380kW - 2222kW

#67

Marine Engine

318kW - 718kW

Horse Power from 412Hp - 959Hp

C Series Engine



The C series diesel engine, is a small-power, four-valve diesel engine with six cylinders that is newly developed by VMAN Company.

Featuring strong power and low fuel consumption and with the emissions conforming to relevant national regulations, C series diesel engine is an ideal supporting power for the middle-end and high-end vehicles and industrial equipments.

Model	Type	Rate Speed (r/min)	Standby Power (kW)	Prime Power (kW)	DIS (L)	Fuel Consumption (L/h)		Firing Sequence	Size (mm)	Flywheel
						0.75	1			
C03A2	L4	1500	28	25	2.5	4.8	6.3	1-3-4-2	858x541x730	SAE4#7.5
C03A1			44	40		7.4	9.8			
C03A			55	50		8.9	11.8			
C03AP			65	60		11.0	14.5			
C04A3	L4		68	62	4.3	10.9	14.4	1-3-4-2	1018x716x989	SAE3#11.5
C04A2			86	78		13.7	18.1		1213x760x1010	
C04A1			115	105		18.5	24.4			
C04A			132	120		21.1	27.9			
C07A1	L6		170	155	6.5	27.6	36.4	1-5-3-6-2-4	1330x789x1079	SAE3#11.5
C07A			187	170	30.2	39.9				
C07AP			205	185	7.2	34.7	45.8			
C10A	L6		258	235	10	43.9	57.9	1-5-3-6-2-4	1852x920x1453	SAE1#14
C10AP		283	258	53.6		70.7				
C03B2	L4	1800	28	25	2.5	4.8	6.3	1-3-4-2	858x541x730	SAE4#7.5
C03B1			44	40		7.5	9.9			
C03B			55	50		9.0	11.9			
C03BP			65	60		11.1	14.6			
C04B3	L4		68	62	4.3	10.9	14.4	1-3-4-2	1018x716x989	SAE3#11.5
C04B2			86	78		13.7	18.1		1123x760x1010	
C04B1			115	105		18.5	24.4			
C04B			132	120		21.1	27.9			
C07B1	L6		175	160	6.5	29.8	39.4	1-5-3-6-2-4	1330x789x1079	SAE3#11.5
C07B			198	180	7.2	36.4	48.0			
C07BP			220	200	36.4	48.0				
C10B	L6		270	245	10	42.6	56.3	1-5-3-6-2-4	1852x920x1453	SAE1#14
C10BP		283	258	54.1		71.4				

C03 Series Engine

RATINGS DEFINITION

The power ratings of Emergency Standby and Prime are in accordance with the standard of ISO8528. Fuel Stop power in accordance with the standard of ISO3046. Electric power (kW) should be estimated by considering generator efficiency, cooling fan power loss and power derating based on altitude and temperature.

STANDBY POWER RATING is applicable for supplying emergency power for the duration of the utility power outage. No overload capability is available for this rating. A standby rated engine should be sized for a maximum of 70% average load factor and 200 hours of operation per year, this includes less than 25 hours per year at the Standby Power rating.

PRIME POWER RATING is available for an unlimited of hours per year in variable load application. Variable load should not exceed 70% average the Prime Power rating during any operating period hours. The total operating time at 100% Prime Power shall not exceed 500 hours per year. 10% overload capability is available for a period of 1 hour within a 12 hours period of operation. Total operating time at the 10% overload power shall not exceed 25 hours per year,

CONTINUOUS POWER RATING is the power that the engine can continue to use under the prescribed speed and the specific environment condition in the normal maintenance period stipulated in the manufacturing plant. Continuous power applicable for supplying utility power at a constant 100% for an unlimited number of hours per year. No overload capability is available for this rating.



GENERAL ENGINE DATA

Engine Model	C03A2	C03A1	C03A	C03AP	C03B2	C03B1	C03B	C03BP
Engine Type	4-Cylinder							
Engine Type	Naturally aspirated	Turbo charged	Turbo charged Intercooled	Turbo charged Intercooled	Naturally aspirated	Turbo charged	Turbo charged Intercooled	Turbo charged Intercooled
Prime power (kW)	25	40	50	60	25	40	50	60
Standby power (kW)	28	44	55	66	28	44	55	66
Continuous power (kW)	20	31	39	46	19	31	39	46
Speed	1500 rpm				1800 rpm			
Bore x stroke	89x100 mm							
Displacement	2.5L							
Compression ratio	17.5 : 1							
Rotation {Looking at flywheel}	Counter clockwise {CCW}							
Firing order	1-3-4-2							
Injection timing	14°BTDC	10°BTDC	10°BTDC	10°BTDC	14°BTDC	10°BTDC	10°BTDC	10°BTDC
Dry weight {W/O cooling system}	230kg	240kg	250kg	250kg	230kg	240kg	250kg	250kg
Dimension {L x W x H}	850x541x730mm							
Flywheel housing	SAE 4 #							
Flywheel	7.5							
Number of teeth on flywheel	117							
Piston speed	5 m/s				6 m/s			

C03 Series Engine

INTAKE & EXHAUST SYSTEM

Engine Model	C03A2	C03A1	C03A	C03AP	C03B2	C03B1	C03B	C03BP
Max.Intake Restriction (kPa)	5							
Max.Exhaust Back Pressure (kPa)	10							
Combustion Air Consumption (m ³ /h)	167	250	316	379	167	250	316	379
Max.Exhaust Temp.(After Turbo)°C)	650	600	600	630	650	600	600	630
Exhaust Gas Flow (m ³ /h)	501	643	812	975	501	643	812	975
Cooling fan air flow (m ³ /min)	105	105	105	105	122	122	122	122

COOLING SYSTEM

Water circulation by centrifugal pump on engine

Engine Model	C03A2	C03A1	C03A	C03B2	C03B1	C03B
Coolant capacity	15L					
Max.Permissible Temperature	96 °C					
Max.Coolant warning Temperature	97 °C					
Max.Coolant Shutdown Temperature	99 °C					
Thermostat Open Temperature	80 °C					
Max.external coolant system restriction	Not available					

Two radiator options are provided, based on allowable maximum Air temperature On radiator inlet (Air On 40 °C) Air On 50 °C

- ATB (Ambient Temperature before Boiling) of generator set varies depending on the engine room ventilation design, even if the same radiator applied. Adequate selection of radiator options by means of the cooling test is highly recommended, and generator set makers are responsible for the selection.

FUEL SYSTEM

In-line pump with integrated, electromagnetic actuator

Engine Model	C03A2	C03A1	C03A	C03AP	C03B2	C03B1	C03B	C03BP
Governor	GAC Digital Pump Governor DGP100-101							
Speed drop	G2 Class (ISO 8528)							
Feed pump	Mechanical type in pump							
Injection nozzle	Multi hole type							
Opening pressure	24 MPa							
Fuel filter	Full flow							
Maximum fuel inlet restriction	100 kPa							
Maximum fuel return restriction	5~20 kPa							
Fuel feed pump Capacity	72 L/h							
Fuel	Diesel fuel							
Fuel consumption								
Standby power- 100% load (L/h)	6.8	10.6	12.8	15.8	6.9	10.7	13.0	15.9
Prime power - 100% load (L/h)	6.3	9.8	11.8	14.5	6.3	9.9	11.9	14.6
- 75% load (L/h)	4.7	7.4	8.9	11.0	4.8	7.5	9.0	11.1
- 50% load (L/h)	3.2	5.0	6.0	7.4	3.2	5.0	6.1	7.5
- 25% load (L/h)	1.6	2.5	3.0	3.7	1.6	2.5	3.1	3.8
Continuous power - 100% load (L/h)	4.9	7.5	9.1	11.2	4.9	7.6	9.2	11.3
Fuel Consumption Ratio (g/kW.h)	210	205	198	203	212	207	200	205

C03 Series Engine

LUBRICATION SYSTEM

Force-feed lubrication by gear pump, lubricating oil cooling water circuit of engine

	Force-feed lubrication by gear pump, lubricating oil cooling water circuit of engine	
Lub.Method	Fully forced pressure feed type	
Oil filter	Full flow, cartridge type	
Lube oil specification	CF-4	
Lube oil pressure	Idle Speed : Min 100 kPa Governed Speed: Min 200 kPa	
Maximum oil temperature	125	
Max.Permissible Oil Temperature	120 °C	
Oil Consumption (as % of fuel consumption)	≤0.2	
Oil capacity	7 L	

ELECTRICAL SYSTEM

Engine Model	C03A2	C03A1	C03A	C03AP	C03B2	C03B1	C03B	C03BP
Charging Alternator Voltage					14 V			
Charging Alternator Capacity					55 A			
Voltage regulator					Built-in type IC regulator			
Starting motor					3.8kW			
Battery Voltage					12VDC			
Battery Capacity					180Ah x 1			
Starting aid (Option)					/			

VALVE SYSTEM

Type	Overhead valve type	
Number of valve	Intake 1, exhaust 1 per cylinder	
Valve lashes at cold	Intake 0.28 mm, Exhaust 0.28 mm	
Valve timing		
	Opening	Close
- Intake valve	14 deg.BTDC	46 deg.ABDC
- Exhaust valve	46 deg.BBDC	14deg.ATDC

C03 SERIES DIESEL ENGINE DRAWING

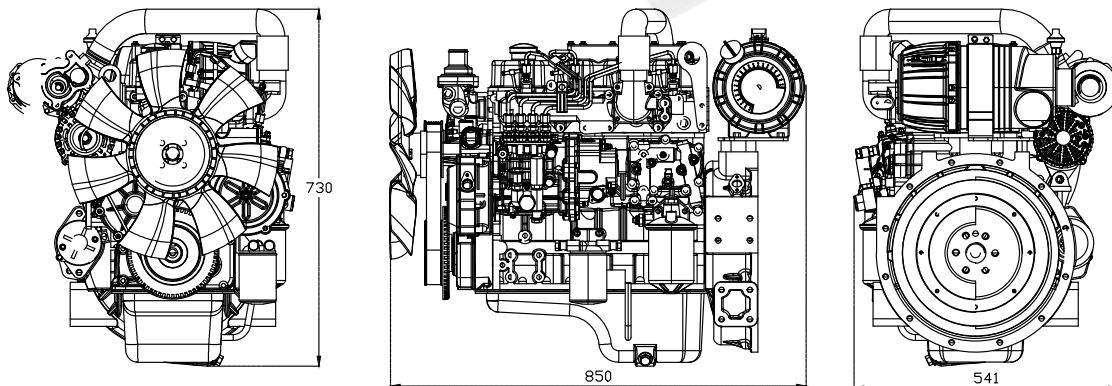

C04 Series Engine

RATINGS DEFINITION

The power ratings of Emergency Standby and Prime are in accordance with the standard of ISO8528. Fuel Stop power in accordance with the standard of ISO3046. Electric power (kW) should be estimated by considering generator efficiency, cooling fan power loss and power derating based on altitude and temperature.

STANDBY POWER RATING is applicable for supplying emergency power for the duration of the utility power outage. No overload capability is available for this rating. A standby rated engine should be sized for a maximum of a 70% average load factor and 200 hours of operation per year, this includes less than 25 hours per year at the Standby Power rating.

PRIME POWER RATING is available for an unlimited of hours per year in variable load application. Variable load should not exceed 70% average the Prime Power rating during any operating period hours., The total operating time at 100% Prime Power shall not exceed 500 hours per year.

10% overload capability is available for a period of 1 hour within a 12 hours period of operation. Total operating time at the 10% overload power shall not exceed 25 hours per year,

CONTINUOUS POWER RATING is the power that the engine can continue to use under the prescribed speed and the specific environment condition in the normal maintenance period stipulated in the manufacturing plant. Continuous power applicable for supplying utility power at a constant 100% for an unlimited number of hours per year. No overload capability is available for this rating.



GENERAL ENGINE DATA

Engine Model	C04A3	C04A2	C04A1	C04A	C04B3	C04B2	C04B1	C04B
Engine Type	4-Cylinder,							
Engine Type	Turbo charged		Turbo charged & intercooled (air to air)		Turbo charged		Turbo charged & intercooled (air to air)	
Prime power (kW)	62	78	105	120	62	78	105	120
Standby power (kW)	68	86	116	132	68	86	116	132
Continuous power (kW)	48	60	81	92	48	60	81	92
Speed	1500 rpm				1800 rpm			
Bore x stroke	105x124 mm							
Displacement	4.3L							
Compression ratio	17.3: 1		16: 1		17.3: 1		16: 1	
Rotation {Looking at flywheel}	Counter clockwise {CCW}							
Firing order	1-3-4-2							
Injection timing	10° BTDC@ 1500 rpm				10° BTDC@ 1800 rpm			
Dry weight {W/O cooling system}	460 kg							
Dimension {L x W x H}	1018x716x989 mm		1123x760x1010 mm		1018x716x989 mm		1123x760x1010 mm	
Flywheel housing	SAE 3 #							
Flywheel	SAE 11.5 #							
Number of teeth on flywheel	127							
Piston speed	6.2 m/s				7.44 m/s			

C04 Series Engine

INTAKE & EXHAUST SYSTEM

Engine Model	C04A3	C04A2	C04A1	C04A	C04B3	C04B2	C04B1	C04B
Max.Intake Restriction (kPa)					6			
Max.Exhaust Back Pressure (kPa)					10			
Combustion Air Consumption (m ³ /h)	336		480		432		600	
Max.Exhaust Temp.(After Turbo°C)	600		600		600		600	
Exhaust Gas Flow (m ³ /h)	792		1146		1020		1404	
Cooling fan air flow (m ³ /min)	180		210		216		252	

COOLING SYSTEM

Water circulation by centrifugal pump on engine

Engine Model	C04A3	C04A2	C04A1	C04A	C04B3	C04B2	C04B1	C04B
Coolant capacity	15 L		15 L		15 L		15 L	
Max.Permissible Temperature	90 °C		87 °C		90 °C		87 °C	
Max.Coolant warning Temperature	96 °C		94 °C		96 °C		94 °C	
Max.Coolant Shutdown Temperature	99 °C		99 °C		99 °C		99 °C	
Thermostat Open Temperature	82 °C		82 °C		82 °C		82 °C	
Max.external coolant system restriction	Not available		Not available		Not available		Not available	

Two radiator options are provided, based on allowable maximum Air temperature On radiator inlet (Air On 40 °C) Air On 50 °C

- ATB (Ambient Temperature before Boiling) of generator set varies depending on the engine room ventilation design, even if the same radiator applied. Adequate selection of radiator options by means of the cooling test is highly recommended, and generator set makers are responsible for the selection.

FUEL SYSTEM

In-line pump with integrated, electromagnetic actuator

Engine Model	C04A3	C04A2	C04A1	C04A	C04B3	C04B2	C04B1	C04B
Governor	Electric type (VMAN DSC 100-07)							
Speed drop	G2 Class (ISO 8528)							
Feed pump	Mechanical type in pump							
Injection nozzle	Multi hole type							
Opening pressure	25 MPa							
Fuel filter	Full flow, Cartridge type with water drain valve							
Maximum fuel inlet restriction	25 kPa							
Maximum fuel return restriction	50 kPa							
Fuel feed pump Capacity	310 L/h							
Fuel	Diesel fuel							
Fuel Consumption								
Standby power- 100% load (L/h)	15.7	19.7	26.5	30.3	15.7	19.7	26.5	30.3
Prime power - 100% load (L/h)	14.4	18.1	24.4	27.9	14.4	18.1	24.4	27.9
- 75% load (L/h)	10.9	13.7	18.5	21.1	10.9	13.7	18.5	21.1
- 50% load (L/h)	7.3	9.2	12.4	14.2	7.3	9.2	12.4	14.2
- 25% load (L/h)	3.7	4.7	6.3	7.2	3.7	4.7	6.3	7.2
Continuous power - 100% load (L/h)	11.1	13.9	18.8	21.5	11.1	13.9	18.8	21.5
Fuel Consumption Ratio (g/kW.h)	195	195	195	195	195	195	195	195

C04 Series Engine

LUBRICATION SYSTEM

Force-feed lubrication by gear pump, lubricating oil cooling water circuit of engine

	Force-feed lubrication by gear pump, lubricating oil cooling water circuit of engine
Lub.Method	Fully forced pressure feed type
Oil filter	Full flow, cartridge type
Lube oil specification	CF-4
Lube oil pressure	Idle Speed : Min 70 kPa Governed Speed: Min 207 kPa
Maximum oil temperature	115 °C
Max.Permissible Oil Temperature	98 °C
Oil Consumption (as % of fuel consumption)	≤0.2
Oil capacity	13 L

ELECTRICAL SYSTEM

Engine Model	C04A3	C04A2	C04A1	C04A	C04B3	C04B2	C04B1	C04B
Charging Alternator Voltage	13.8V or 28V							
Charging Alternator Capacity	35A							
Voltage regulator	Built-in type IC regulator							
Starting motor	4.5kW/24V or 4.2kW/12V							
Battery Voltage	24V or 12V							
Battery Capacity	2* 120Ah or 120Ah (recommended)							
Starting aid (Option)	Block heater (Min. Temperature for Unaided Cold Start -10°C)							

VALVE SYSTEM

Type	Overhead valve type		
Number of valve	Intake 2, exhaust 2 per cylinder		
Valve lashes at cold	Intake 0.25 mm, Exhaust 0.50 mm		
Valve timing	Opening		Close
- Intake valve	20.9 deg.BTDC		44.9 deg.ABDC
- Exhaust valve	51.7 deg.BBDC		11.7 deg.ATDC

C04 SERIES DIESEL ENGINE DRAWING

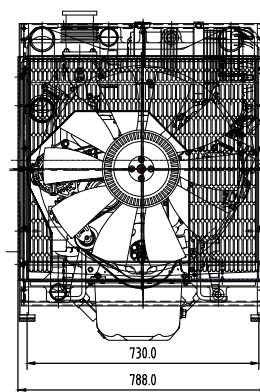
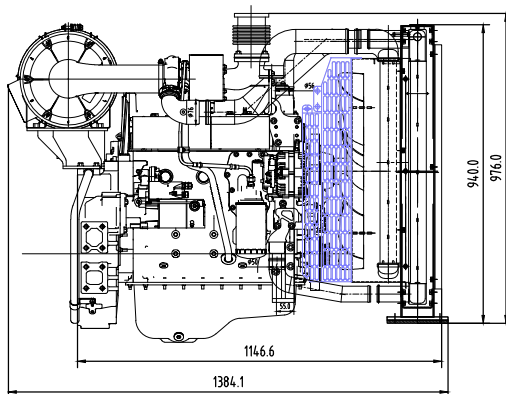

C07 Series Engine

RATINGS DEFINITION

The power ratings of Emergency Standby and Prime are in accordance with the standard of IS08528. Fuel Stop power in accordance with the standard of ISO3046. Electric power (kW) should be estimated by considering generator efficiency, cooling fan power loss and power derating based on altitude and temperature.

STANDBY POWER RATING is applicable for supplying emergency power for the duration of the utility power outage. No overload capability is available for this rating. A standby rated engine should be sized for a maximum of 70% average load factor and 200 hours of operation per year, this includes less than 25 hours per year at the Standby Power rating.

PRIME POWER RATING is available for an unlimited of hours per year in variable load application. Variable load should not exceed 70% average the Prime Power rating during any operating period hours., The total operating time at 100% Prime Power shall not exceed 500 hours per year.

10% overload capability is available for a period of 1 hour within a 12 hours period of operation. Total operating time at the 10% overload power shall not exceed 25 hours per year,

CONTINUOUS POWER RATING is the power that the engine can continue to use under the prescribed speed and the specific environment condition in the normal maintenance period stipulated in the manufacturing plant. Continuous power applicable for supplying utility power at a constant 100% for an unlimited number of hours per year. No overload capability is available for this rating.



GENERAL ENGINE DATA

Engine Model	C07A1	C07A	C07AP	C07B1	C07B	C07BP
Engine Type	6-Cylinder, Turbo charged & intercooled (air to air)					
Prime Power (kW)	155	170	185	160	180	191
Standby Power (kW)	171	187	204	176	198	210
Continuous Power (kW)	119	131	142	123	139	147
Speed	1500 rpm			1800 rpm		
Bore x stroke (mm)	105x124		108x130	105x124		108x130
Displacement	6.5 L		7.2L	6.5L		7.2L
Compression ratio	16 : 1		17.3 : 1	16 : 1		17.3 : 1
Rotation {Looking at flywheel}	Counter clockwise {CCW}					
Firing order	1-5-3-6-2-4					
Injection timing (BTDC)	12°±0.5°		10.5±0.5°	12°±0.5°		10.5±0.5°
Dry weight {W/O cooling system}	600 kg					
Dimension with radiator {L x W x H}	1461x 870x1206 mm					
Flywheel housing	SAE 3 #					
Flywheel	SAE (11-1/2) #					
Number of teeth on flywheel	127					
Piston speed	6.2 m/s		6.5 m/s	7.44 m/s		7.8 m/s

C07 Series Engine

INTAKE & EXHAUST SYSTEM

Engine Model	C07A1	C07A	C07AP	C07B1	C07B	C07BP
Max.Intake Restriction (kPa)	6					
Max.Exhaust Back Pressure (kPa)	10					
Combustion Air Consumption (m ³ /h)	714		777		882	936
Max.Exhaust Temp.(After Turbo°C)	600					
Exhaust Gas Flow (m ³ /h)	1686		1835		2088	2216
Cooling fan air flow (m ³ /min)	252			277		

COOLING SYSTEM

Water circulation by centrifugal pump on engine

Coolant capacity	32 L
Max.Permissible Temperature	90 °C
Max.Coolant warning Temperature	95 °C
Max.Coolant Shutdown Temperature	99 °C
Thermostat Open Temperature	82 °C
Max.external coolant system restriction	Not available

Two radiator options are provided, based on allowable maximum Air temperature On radiator inlet (Air On 40 °C) Air On 50 °C

- ATB (Ambient Temperature before Boiling) of generator set varies depending on the engine room ventilation design, even if the same radiator applied. Adequate selection of radiator options by means of the cooling test is highly recommended, and generator set makers are responsible for the selection.

FUEL SYSTEM

In-line pump with integrated, electromagnetic actuator

Engine Model	C07A1	C07A	C07AP	C07B1	C07B	C07BP
Governor	Electric type (Woodward Gov. / VMAN Gov.)					
Speed drop	G2 Class (ISO 8528)					
Feed pump	Mechanical type in pump					
Injection nozzle	Multi hole type					
Opening pressure	25 MPa					
Fuel filter	Full flow, Cartridge type with water drain valve					
Maximum fuel inlet restriction	25 kPa					
Maximum fuel return restriction	50 kPa					
Fuel feed pump Capacity	450 L/h					
Fuel	Diesel fuel					
Fuel consumption						
Standby power- 100% load (L/h)	39.6	43.4	49.9	42.9	48.3	52.2
Prime Power - 100% load (L/h)	36.4	39.9	45.8	39.4	44.4	48.0
- 75% load (L/h)	27.5	30.2	34.7	29.9	33.6	36.3
- 50% load (L/h)	18.5	20.3	23.4	20.1	22.6	24.5
- 25% load (L/h)	9.4	10.3	11.8	10.2	11.4	12.4
Continous power - 100% load (L/h)	28.0	30.7	35.3	30.4	34.2	36.9
Fuel Consumption Ratio (g/kW.h)	197	197	208	207	207	211

C07 Series Engine

LUBRICATION SYSTEM

Force-feed lubrication by gear pump, lubricating oil cooling water circuit of engine

	Force-feed lubrication by gear pump, lubricating oil cooling water circuit of engine
Lub.Method	Fully forced pressure feed type
Oil filter	Full flow, cartridge type
Lube oil specification	CF-4
Lube oil pressure	Idle Speed : Min 80 kPa Governed Speed: Min 200 kPa
Maximum oil temperature	115 °C
Max.Permissible Oil Temperature	98 °C
Oil Consumption (as % of fuel consumption)	≤0.2
Oil capacity	18 L

ELECTRICAL SYSTEM

Engine Model	C07A1	C07A	C07AP	C07B1	C07B	C07AP	C07BP
Charging Alternator Voltage				28V			
Charging Alternator Capacity				35A			
Voltage regulator				Built-in type IC regulator			
Starting motor				5.5kW			
Battery Voltage				24V			
Battery Capacity		2 * 120 Ah (recommended)			165 Ah (recommended)		
Starting aid (Option)		Block heater (Min. Temperature for Unaided Cold Start -10°C)					

VALVE SYSTEM

Type	Overhead valve type	
Number of valve	Intake 2, exhaust 2 per cylinder	
Valve lashes at cold	Intake 0.25 mm, Exhaust 0.50 mm	
Valve timing	Opening	Close
- Intake valve	20.9 deg.BTDC	44.9 deg.ABDC
- Exhaust valve	51.7 deg.BBDC	11.7 deg.ATDC

C07 SERIES DIESEL ENGINE DRAWING

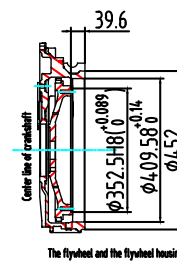
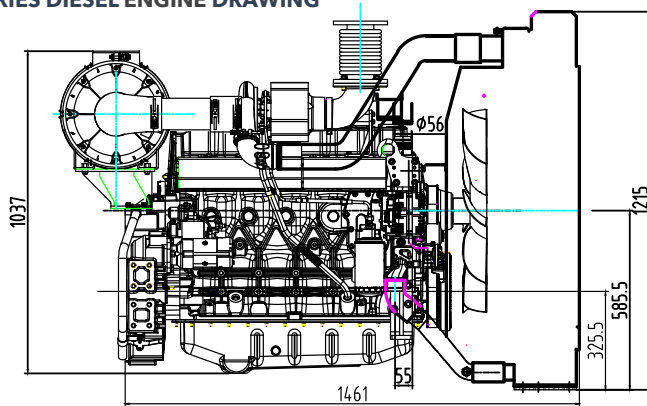

C10 Series Engine

RATINGS DEFINITION

The power ratings of Emergency Standby and Prime are in accordance with the standard of ISO8528. Fuel Stop power in accordance with the standard of ISO3046. Electric power (kW) should be estimated by considering generator efficiency, cooling fan power loss and power derating based on altitude and temperature.

STANDBY POWER RATING is applicable for supplying emergency power for the duration of the utility power outage. No overload capability is available for this rating. A standby rated engine should be sized for a maximum of 70% average load factor and 200 hours of operation per year, this includes less than 25 hours per year at the Standby Power rating.

PRIME POWER RATING is available for an unlimited of hours per year in variable load application. Variable load should not exceed 70% average the Prime Power rating during any operating period hours., The Total operating time at 100% Prime Power shall not exceed 500 hours per year.

10% overload capability is available for a period of 1 hour within a 12 hours period of operation. Total operating time at the 10% overload power shall not exceed 25 hours per year,

CONTINUOUS POWER RATING is the power that the engine can continue to use under the prescribed speed and the specific environment condition in the normal maintenance period stipulated in the manufacturing plant. Continuous power applicable for supplying utility power at a constant 100% for an unlimited number of hours per year. No overload capability is available for this rating.



GENERAL ENGINE DATA

Engine Model	C10A	C10AP	C10B	C10BP
Engine Type	Line type 6 -Cylinder, Turbo charged & intercooled (air to air)			
Prime Power (kW)	235	258	235	258
Standby Power (kW)	259	284	259	284
Continuous Power (kW)	181	199	181	199
Speed	1500 rpm		1800 rpm	
Bore x stroke	126 x130 mm			
Displacement	9.726 L			
Compression ratio	17:1			
Rotation {Looking at flywheel}	Counter clockwise {CCW}			
Firing order	1-5-3-6-2-4			
Injection timing	13.5°±2.5° BTDC @ 1500 rpm		13.5°±2.5° BTDC@ 1800 rpm	
Dry weight {W/O cooling system}	1000 kg			
Dimension {L x W x H}	1852 x920 x1453 mm			
Flywheel housing	SAE 1 #			
Flywheel	14			
Number of teeth on flywheel	127			
Piston speed	6.5 m/s		7.8 m/s	

C07 Series Engine

INTAKE & EXHAUST SYSTEM

Engine Model	C10A	C10AP	C10B	C10BP
Max.Intake Restriction (kPa)	5	5	5	5
Max.Exhaust Back Pressure (kPa)	8	8	8	8
Combustion Air Consumption (m ³ /h)	1126	1126	1848	1848
Max.Exhaust Temp.(After Turbo°C)	550	550	550	550
Exhaust Gas Flow (m ³ /h)	2216	2438	2850	3135
Cooling fan are flow(m ³ /min)	362		401	

COOLING SYSTEM

Water circulation by centrifugal pump on engine

Coolant capacity	45 L
Max.Permissible Temperature	90 °C
Max.Coolant warning Temperature	95 °C
Max.Coolant Shutdown Temperature	99 °C
Thermostat Open Temperature	71 °C
Max.external coolant system restriction	Not available

Two radiator options are provided, based on allowable maximum Air temperature On radiator inlet (Air On 40 °C) Air On 50 °C

- ATB (Ambient Temperature before Boiling) of generator set varies depending on the engine room ventilation design, even if the same radiator applied. Adequate selection of radiator options by means of the cooling test is highly recommended, and generator set makers are responsible for the selection.

FUEL SYSTEM

In-line pump with integrated, electromagnetic actuator

Engine Model	C10A	C10AP	C10B	C10BP
Governor	Electric type			
Speed drop	G2 Class (ISO 8528)			
Feed pump	Mechanical type in pump			
Injection nozzle	Multi hole type			
Opening pressure	28 MPa			
Fuel filter	Full flow, Cartridge type with water drain valve			
Maximum fuel inlet restriction	30 kPa			
Maximum fuel return restriction	60 kPa			
Fuel feed pump Capacity	630 L/h			
Fuel	Diesel fuel			
Fuel consumption				
Standby power- 100% load (L/h)	62.5	67.9	65.5	71.2
Prime Power - 100% load (L/h)	57.4	62.4	60.1	65.4
- 75% load (L/h)	43.4	47.2	45.6	49.6
- 50% load (L/h)	29.2	31.8	30.7	33.4
- 25% load (L/h)	14.8	16.1	15.5	16.8
Continous power - 100% load (L/h)	44.2	48.0	46.3	50.4
Fuel Consumption Ratio (g/kW.h)	205	203	215	213

C10 Series Engine

LUBRICATION SYSTEM

Force-feed lubrication by gear pump, lubricating oil cooling water circuit of engine

	Force-feed lubrication by gear pump, lubricating oil cooling water circuit of engine	
Lub.Method	Fully forced pressure feed type	
Oil filter	Full flow, cartridge type	
Lube oil specification	CF-4	
Lube oil pressure	Idle Speed : Min 98 kPa Governed Speed: Min 294 kPa	
Maximum oil temperature	115 °C	
Max.Permissible Oil Temperature	98 °C	
Oil Consumption (as % of fuel consumption)	≤0.3	
Oil capacity	24 L	

ELECTRICAL SYSTEM

Charging Alternator Voltage	28V	
Charging Alternator Capacity	45A	
Voltage regulator	Built-in type IC regulator	
Starting motor	8.5kW	
Battery Voltage	24V	
Battery Capacity	2 x 150 Ah (recommended)	
Starting aid (Option)	Block heater (Min. Temperature for Unaided Cold Start -10°C)	

VALVE SYSTEM

Type	Overhead valve type	
Number of valve	Intake 2, exhaust 2 per cylinder	
Valve lashes at cold	Intake 0.25 mm, Exhaust 0.50 mm	
Valve timing	Opening	Close
- Intake valve	24 deg.BTDC	36 deg.ABDC
- Exhaust valve	63 deg.BBDC	27 deg.ATDC

C10 SERIES DIESEL ENGINE DRAWING

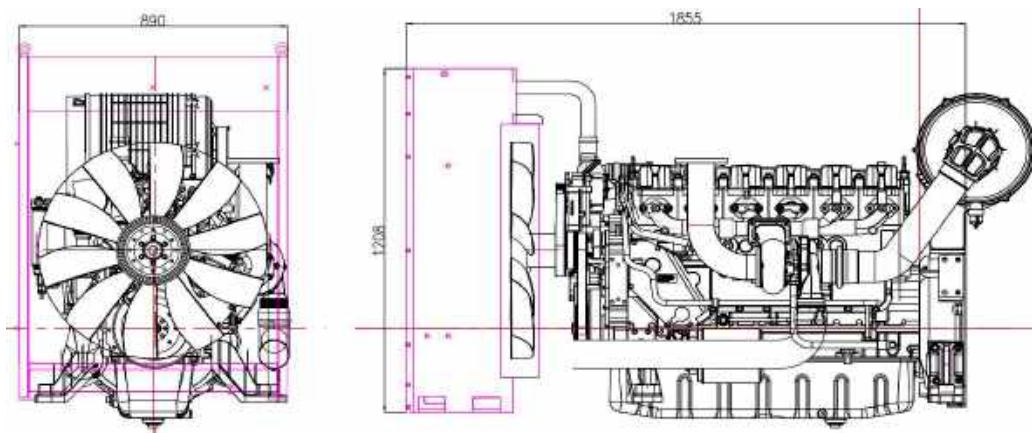

CE Series Engine

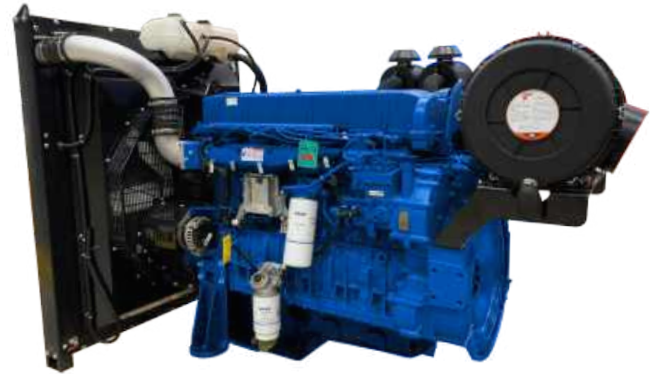

The CE series diesel engine, Adopt in-line 6 cylinders, integral cylinder head, four valves, overhead camshaft, rear gear chamber technology; Professional High pressure common rail fuel injection system;

Instant response speed is fast, 0-270KW sudden increase and decrease, power generation frequency fluctuation is 50Hz/60Hz $\pm 1\%$;

The overhaul time of the engine reaches 25,000 hours and meets the non-road T3 emission standard.

Model	Type	Rate Speed	Standby Power	Prime Power	DIS (L)	Fuel Consumption (L/h)		Firing Sequence	Size	Flywheel
		(r/min)	(kW)	(kW)		0.75	1		(mm)	
CE10A	L6	1500	325	295	9.84	53.5	70.6	1-5-3-6-2-4	1915 x 934 x 1478	SAE1#14
CE10B		1800	340	310		56.7	74.9			
CE12A	L6	1500	390	355	11.8	61.4	81.1	1-5-3-6-2-4	1997 x 921 x 1562	SAE1#14
CE12B		1800	390	355		64.7	85.4			
CE13A	L6	1500	455	415	12.8	73.4	96.8	1-5-3-6-2-4	2000 x 946 x 1557	SAE1#14
CE13B		1800	455	415		76.3	100.8			
CE13AP	L6	1500	475	450	12.8	79.1	104.5	1-5-3-6-2-4	2000 x 946 x 1557	SAE1#14
CE13BP		1800	475	450		82.4	108.8			

CE10 Series Engine

RATINGS DEFINITION

The power ratings of Emergency Standby and Prime are in accordance with the standard of ISO8528. Fuel Stop power in accordance with the standard of ISO3046. Electric power (kW) should be estimated by considering generator efficiency, cooling fan power loss and power derating based on altitude and temperature.

STANDBY POWER RATING is applicable for supplying emergency power for the duration of the utility power outage. No overload capability is available for this rating. A standby rated engine should be sized for a maximum of 70% average load factor and 200 hours of operation per year, this includes less than 25 hours per year at the Standby Power rating.

PRIME POWER RATING is available for an unlimited of hours per year in variable load application. Variable load should not exceed 70% average the Prime Power rating during any operating period hours., The Total operating time at 100% Prime Power shall not exceed 500 hours per year.

10% overload capability is available for a period of 1 hour within a 12 hours period of operation. Total operating time at the 10% overload power shall not exceed 25 hours per year,

CONTINUOUS POWER RATING is the power that the engine can continue to use under the prescribed speed and the specific environment condition in the normal maintenance period stipulated in the manufacturing plant. Continuous power applicable for supplying utility power at a constant 100% for an unlimited number of hours per year. No overload capability is available for this rating.



GENERAL ENGINE DATA

Engine Model	CE10A	CE10B
Engine Type	Line type 6 -Cylinder, Turbo charged & intercooled (air to air)	
Prime Power (kW)	295	310
Standby Power (kW)	325	340
Continuous Power (kW)	295	310
Speed	1500 rpm	1800 rpm
Bore x stroke	118 X 150 mm	
Displacement	9.84 L	
Compression ratio	17:1	
Rotation {Looking at flywheel}	Counter clockwise {CCW}	
Firing order	1-5-3-6-2-4	
Injection timing	7°±3° BTDC @ 1500 rpm	9°±2.5° BTDC@ 1800 rpm
Dry weight {W/O cooling system}	980 kg	
Dimension {L x W x H}	1915 x 934 x 1478 mm	
Flywheel housing	SAE 1 #	
Flywheel	14	
Number of teeth on flywheel	152	
Piston speed	7.5 m/s	9 m/s

CE10 Series Engine

INTAKE & EXHAUST SYSTEM

Engine Model	CE10A	CE10B
Max.Intake Restriction (kPa)	3.5	3.5
Max.Exhaust Back Pressure (kPa)	13	13
Combustion Air Consumption (m ³ /h)	1350	1512
Max.Exhaust Temp.(After Turbo°C)	590	590
Exhaust Gas Flow (m ³ /h)	3375	3780
Cooling fan are flow(m ³ /min)	461	603

COOLING SYSTEM

Water circulation by centrifugal pump on engine

Coolant capacity	42 L
Max.Permissible Temperature	105 °C
Max.Coolant warning Temperature	102 °C
Max.Coolant Shutdown Temperature	104 °C
Thermostat Open Temperature	85 °C start open; 95 °C full open
Max.external coolant system restriction	Cooling water pump inlet pressure > 30kpa

Two radiator options are provided, based on allowable maximum Air temperature On radiator inlet (Air On 40 °C) Air On 50 °C

- ATB (Ambient Temperature before Boiling) of generator set varies depending on the engine room ventilation design, even if the same radiator applied. Adequate selection of radiator options by means of the cooling test is highly recommended, and generator set makers are responsible for the selection.

FUEL SYSTEM

In-line pump with integrated, electromagnetic actuator

Engine Model	CE10A	CE10B
Governor	Common rail (Bosch's ECM)	
Speed drop	G2 Class (ISO 8528)	
Feed pump	Common rail	
Injection nozzle	Multi hole type	
Opening pressure	25 MPa	
Fuel filter	Full flow, Cartridge type with water drain valve	
Maximum fuel inlet restriction	65 kPa	
Maximum fuel return restriction	20 kPa	
Fuel feed pump Capacity	260 L/h	
Fuel	Diesel fuel	
Fuel consumption		
Standby power- 100% load (L/h)	76.9	81.6
Prime Power - 100% load (L/h)	70.6	74.9
- 75% load (L/h)	53.5	56.7
- 50% load (L/h)	36.0	38.2
- 25% load (L/h)	18.2	19.3
Continous power - 100% load (L/h)	70.6	74.9
Fuel Consumption Ratio (g/kW.h)	201	203

CE10 Series Engine

LUBRICATION SYSTEM

Force-feed lubrication by gear pump, lubricating oil cooling water circuit of engine

	Force-feed lubrication by gear pump, lubricating oil cooling water circuit of engine
Lub.Method	Fully forced pressure feed type
Oil filter	Full flow, cartridge type
Lube oil specification	CH-4
Lube oil pressure	Min 150 kPa
Maximum oil temperature	120 °C
Max.Permissible Oil Temperature	116 °C
Oil Consumption (as % of fuel consumption)	≤0.1
Oil capacity	34.5 L

ELECTRICAL SYSTEM

Charging Alternator Voltage	28V
Charging Alternator Capacity	70A
Voltage regulator	Built-in type IC regulator
Starting motor	7.5kW
Battery Voltage	24V
Battery Capacity	2 x 150 Ah (recommended)
Starting aid (Option)	Block heater (Min. Temperature for Unaided Cold Start -10°C)

VALVE SYSTEM

Type	Overhead valve type	
Number of valve	Intake 2, exhaust 2 per cylinder	
Valve lashes at cold	Intake 0.4 mm, Exhaust 0.6 mm	
Valve timing	Opening	Closing
- Intake valve	12.2 deg.BTDC	14.4 deg.ABDC
- Exhaust valve	52.3 deg.BBDC	14.8 deg.ATDC

CE10 SERIES DIESEL ENGINE DRAWING

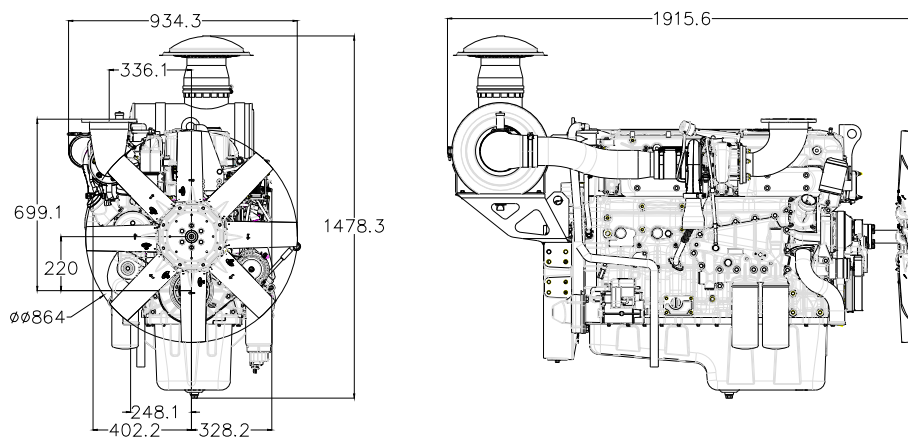

CE12 Series Engine

RATINGS DEFINITION

The power ratings of Emergency Standby and Prime are in accordance with the standard of ISO8528. Fuel Stop power in accordance with the standard of ISO3046. Electric power (kW) should be estimated by considering generator efficiency, cooling fan power loss and power derating based on altitude and temperature.

STANDBY POWER RATING is applicable for supplying emergency power for the duration of the utility power outage. No overload capability is available for this rating. A standby rated engine should be sized for a maximum of 70% average load factor and 200 hours of operation per year, this includes less than 25 hours per year at the Standby Power rating.

PRIME POWER RATING is available for an unlimited of hours per year in variable load application. Variable load should not exceed 70% average the Prime Power rating during any operating period hours., The Total operating time at 100% Prime Power shall not exceed 500 hours per year.

10% overload capability is available for a period of 1 hour within a 12 hours period of operation. Total operating time at the 10% overload power shall not exceed 25 hours per year,

CONTINUOUS POWER RATING is the power that the engine can continue to use under the prescribed speed and the specific environment condition in the normal maintenance period stipulated in the manufacturing plant. Continuous power applicable for supplying utility power at a constant 100% for an unlimited number of hours per year. No overload capability is available for this rating.



GENERAL ENGINE DATA

Engine Model	CE12A	CE12B
Engine Type	Line type 6 -Cylinder, Turbo charged & intercooled (air to air)	
Prime Power (kW)	355	355
Standby Power (kW)	391	391
Continuous Power (kW)	355	355
Speed	1500 rpm	1800 rpm
Bore x stroke	128 x 153 mm	
Displacement	11.81 L	
Compression ratio	17:1	
Rotation {Looking at flywheel}	Counter clockwise {CCW}	
Firing order	1-5-3-6-2-4	
Injection timing	4.5°±2.5° BTDC @ 1500 rpm	7.5°±3° BTDC@ 1800 rpm
Dry weight {W/O cooling system}	1065 kg	
Dimension {L x W x H}	1997 x 921 x 1562 mm	
Flywheel housing	SAE 1 #	
Flywheel	14	
Number of teeth on flywheel	143	
Piston speed	7.6 m/s	9.2 m/s

CE12 Series Engine

INTAKE & EXHAUST SYSTEM

Engine Model	CE12A	CE12B
Max.Intake Restriction (kPa)	3.5	3.5
Max.Exhaust Back Pressure (kPa)	15	15
Combustion Air Consumption (m ³ /h)	1710	1846
Max.Exhaust Temp.(After Turbo°C)	590	590
Exhaust Gas Flow (m ³ /h)	4050	4374
Cooling fan are flow(m ³ /min)	461	603

COOLING SYSTEM

Water circulation by centrifugal pump on engine

Coolant capacity	45 L
Max.Permissible Temperature	105 °C
Max.Coolant warning Temperature	102 °C
Max.Coolant Shutdown Temperature	104 °C
Thermostat Open Temperature	85 °C start open; 95 °C full open
Max.external coolant system restriction	Cooling water pump inlet pressure > 30kpa

Two radiator options are provided, based on allowable maximum Air temperature On radiator inlet (Air On 40 °C) Air On 50 °C

- ATB (Ambient Temperature before Boiling) of generator set varies depending on the engine room ventilation design, even if the same radiator applied. Adequate selection of radiator options by means of the cooling test is highly recommended, and generator set makers are responsible for the selection.

FUEL SYSTEM

In-line pump with integrated, electromagnetic actuator

Engine Model	CE12A	CE12B
Governor	Common rail (Bosch's ECM)	
Speed drop	G2 Class (ISO 8528)	
Feed pump	Common rail	
Injection nozzle	Multi hole type	
Opening pressure	25 MPa	
Fuel filter	Full flow, Cartridge type with water drain valve	
Maximum fuel inlet restriction	65 kPa	
Maximum fuel return restriction	20 kPa	
Fuel feed pump Capacity	260 L/h	
Fuel	Diesel fuel	
Fuel consumption		
Standby power- 100% load (L/h)	88.4	93.0
Prime Power - 100% load (L/h)	81.1	85.4
- 75% load (L/h)	61.5	64.7
- 50% load (L/h)	41.4	43.5
- 25% load (L/h)	20.9	22.0
Continuous power - 100% load (L/h)	81.1	85.4
Fuel Consumption Ratio (g/kW.h)	192	202

CE12 Series Engine

LUBRICATION SYSTEM

Force-feed lubrication by gear pump, lubricating oil cooling water circuit of engine

	Force-feed lubrication by gear pump, lubricating oil cooling water circuit of engine
Lub.Method	Fully forced pressure feed type
Oil filter	Full flow, cartridge type
Lube oil specification	CH-4
Lube oil pressure	Min 150 kPa
Maximum oil temperature	120 °C
Max.Permissible Oil Temperature	116 °C
Oil Consumption (as % of fuel consumption)	≤0.1
Oil capacity	38 L

ELECTRICAL SYSTEM

Charging Alternator Voltage	28V
Charging Alternator Capacity	70A
Voltage regulator	Built-in type IC regulator
Starting motor	7.5kW
Battery Voltage	24V
Battery Capacity	2 x 150 Ah (recommended)
Starting aid (Option)	Block heater (Min. Temperature for Unaided Cold Start -10°C)

VALVE SYSTEM

Type	Overhead valve type	
Number of valve	Intake 2, exhaust 2 per cylinder	
Valve lashes at cold	Intake 0.4 mm, Exhaust 0.65 mm	
Valve timing	Opening	Closing
- Intake valve	10.8 deg.BTDC	29.2 deg.ABDC
- Exhaust valve	49.7 deg.BBDC	11.3 deg.ATDC

CE12 SERIES DIESEL ENGINE DRAWING

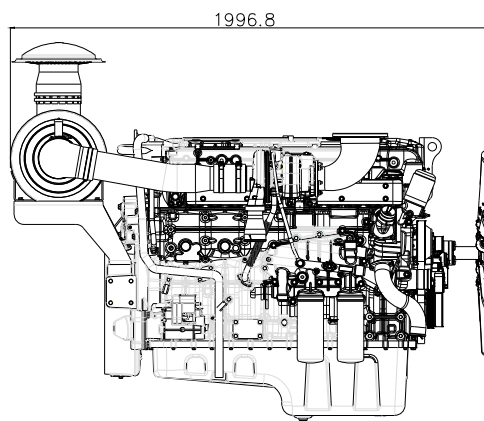
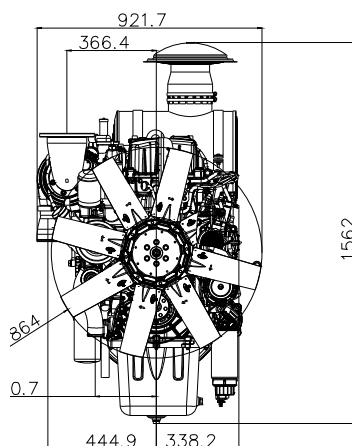

CE13 Series Engine

RATINGS DEFINITION

The power ratings of Emergency Standby and Prime are in accordance with the standard of ISO8528. Fuel Stop power in accordance with the standard of ISO3046. Electric power (kW) should be estimated by considering generator efficiency, cooling fan power loss and power derating based on altitude and temperature.

STANDBY POWER RATING is applicable for supplying emergency power for the duration of the utility power outage. No overload capability is available for this rating. A standby rated engine should be sized for a maximum of 70% average load factor and 200 hours of operation per year, this includes less than 25 hours per year at the Standby Power rating.

PRIME POWER RATING is available for an unlimited of hours per year in variable load application. Variable load should not exceed 70% average the Prime Power rating during any operating period hours., The Total operating time at 100% Prime Power shall not exceed 500 hours per year.

10% overload capability is available for a period of 1 hour within a 12 hours period of operation. Total operating time at the 10% overload power shall not exceed 25 hours per year,

CONTINUOUS POWER RATING is the power that the engine can continue to use under the prescribed speed and the specific environment condition in the normal maintenance period stipulated in the manufacturing plant. Continuous power applicable for supplying utility power at a constant 100% for an unlimited number of hours per year. No overload capability is available for this rating.



GENERAL ENGINE DATA

Engine Model	CE13A	CE13AP	CE13B	CE13BP
Engine Type	Line type 6 -Cylinder, Turbo charged & intercooled (air to air)			
Prime Power (kW)	415	450	415	450
Standby Power (kW)	455	475	455	475
Continuous Power (kW)	415	450	415	450
Speed	1500 rpm		1800 rpm	
Bore x stroke	130 x 161 mm			
Displacement	12.8 L			
Compression ratio	17:1			
Rotation {Looking at flywheel}	Counter clockwise {CCW}			
Firing order	1-5-3-6-2-4			
Injection timing	4°±3.5° BTDC @ 1500 rpm		10°±1.5° BTDC@ 1800 rpm	
Dry weight {W/O cooling system}	1183 kg			
Dimension {L x W x H}	2000 x 946 x 1557 mm			
Flywheel housing	SAE 1 #			
Flywheel	14			
Number of teeth on flywheel	143			
Piston speed	8.1 m/s	8.06 m/s	9.7 m/s	9.66 m/s

CE13 Series Engine

INTAKE & EXHAUST SYSTEM

Engine Model	CE13A	CE13AP	CE13B	CE13BP
Max.Intake Restriction (kPa)	3.5	3.5	3.5	3.5
Max.Exhaust Back Pressure (kPa)	15	11	21	11
Combustion Air Consumption (m ³ /h)	1870	2050	2270	2489
Max.Exhaust Temp.(After Turbo)°C	590	566	590	575
Exhaust Gas Flow (m ³ /h)	4680	5100	5050	5405
Cooling fan are flow(m ³ /min)	533		670	

COOLING SYSTEM

Water circulation by centrifugal pump on engine

Coolant capacity	45 L
Max.Permissible Temperature	105 °C
Max.Coolant warning Temperature	102 °C
Max.Coolant Shutdown Temperature	104 °C
Thermostat Open Temperature	85 °C start open; 95 °C full open
Max.external coolant system restriction	Cooling water pump inlet pressure > 30kpa

Two radiator options are provided, based on allowable maximum Air temperature On radiator inlet (Air On 40 °C) Air On 50 °C

- ATB (Ambient Temperature before Boiling) of generator set varies depending on the engine room ventilation design, even if the same radiator applied. Adequate selection of radiator options by means of the cooling test is highly recommended, and generator set makers are responsible for the selection.

FUEL SYSTEM

In-line pump with integrated, electromagnetic actuator

Engine Model	CE13A	CE13AP	CE13B	CE13BP
Governor	Common rail (Bosch's ECM)			
Speed drop	G2 Class (ISO 8528)			
Feed pump	Common rail			
Injection nozzle	Multi hole type			
Opening pressure	25 MPa			
Fuel filter	Full flow, Cartridge type with water drain valve			
Maximum fuel inlet restriction	65 kPa			
Maximum fuel return restriction	20 kPa			
Fuel feed pump Capacity	260 L/h			
Fuel	Diesel fuel			
Fuel consumption				
Standby power- 100% load (L/h)	105.5	113.8	109.8	118.4
Prime Power - 100% load (L/h)	96.8	104.5	100.8	108.8
- 75% load (L/h)	73.4	79.1	76.3	82.4
- 50% load (L/h)	49.4	53.3	51.4	55.5
- 25% load (L/h)	24.9	26.9	26.0	28.0
Continous power - 100% load (L/h)	96.8	104.5	100.8	108.8
Fuel Consumption Ratio (g/kW.h)	196	195	204	203

CE13 Series Engine

LUBRICATION SYSTEM

Force-feed lubrication by gear pump, lubricating oil cooling water circuit of engine

	Force-feed lubrication by gear pump, lubricating oil cooling water circuit of engine
Lub.Method	Fully forced pressure feed type
Oil filter	Full flow, cartridge type
Lube oil specification	CH-4
Lube oil pressure	Min 150 kPa
Maximum oil temperature	120 °C
Max.Permissible Oil Temperature	120 °C
Oil Consumption (as % of fuel consumption)	≤0.1
Oil capacity	41 L

ELECTRICAL SYSTEM

Charging Alternator Voltage	28V
Charging Alternator Capacity	70A
Voltage regulator	Built-in type IC regulator
Starting motor	7.5kW
Battery Voltage	24V
Battery Capacity	2 x 150 Ah (recommended)
Starting aid (Option)	Block heater (Min. Temperature for Unaided Cold Start -10°C)

VALVE SYSTEM

Type	Overhead valve type	
Number of valve	Intake 2, exhaust 2 per cylinder	
Valve lashes at cold	Intake 0.4 mm, Exhaust 0.65 mm	
Valve timing	Opening	Closing
- Intake valve	10.8 deg.BTDC	29.2 deg.ABDC
- Exhaust valve	49.7 deg.BBDC	11.3 deg.ATDC

CE13 SERIES DIESEL ENGINE DRAWING

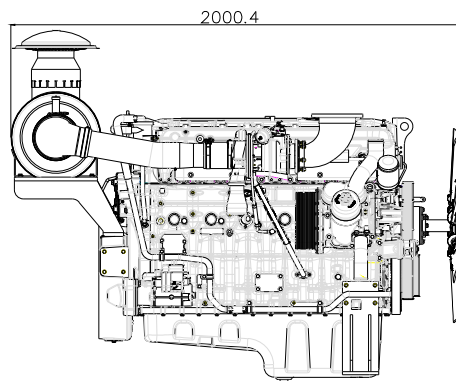
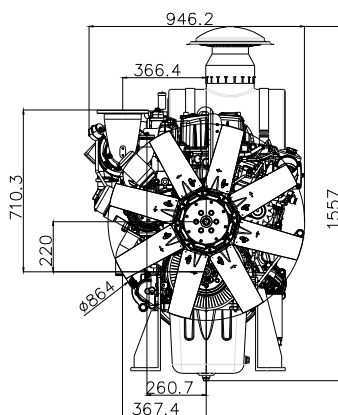

D Series Engine

The D Series Engine, VMAN imports advanced design and technology, production and management from Europe and the United States. The engine is in V-type and gets the technical feature of low compression-ratio and body structure reinforcing, which makes it much more reliable, powerful and lower noise.

The engine is easy to maintain and install and barely break down. The engine can always be used at the harsh climatic conditional regions of heat, cold and arid. Therefore, all these features make it the ideal power of generator, marine engine, auxiliary engine and various engineering machinery.

All series engines gets optimization of structural design by doing 3D modeling and having a finite element strength analysis, which makes diesel engines power get better improvement, at least 100kg lighter than other engines of the same power level.

Model	Type	Rate Speed	Standby Power	Prime Power	Displacement	Fuel Consumption (L/h)		Firing Sequence	Size	Flywheel	
		(r/min)	(kW)	(kW)		(L)	0.75		1.0		(mm)
D11A2	V6	1500	264	240	10.964	41.6	54.9	1-4-2-5-3-6	1251x1389x1288	SAE1#14	
D11A1			292	265		46.1	60.9				
D11A			314	285		50.1	66.2				
D11			360	320		58.9	77.8				
D15A2	V8		363	330	14.618	58.9	77.8	1-5-7-2-6-3-4-8	1661x1392x1307		
D15A1			415	365		64.5	85.2				
D15A			445	405		74.5	98.4				
D15			500	450		83.2	109.8				
D22A3	V12		505	455	21.927	80.8	106.7	1-12-5-8-3-10-6-7-2-1-4-9	1995x1392x1312		SAE1#14
D22A2			565	515		91.5	120.8				
D22A		606	555	96.6		127.5					
D22		700	630	114.8		151.5					
D22Z		735	660		122.0	161.1					
D30A3	V16	780	705	29.235	125.9	166.2	1-15-6-12-8-5-16-7-1-4-9-2-14-10-3-13	2340x1392x1360	SAE0#18		
D30A2		880	795		141.2	186.4					
D30A1		960	875		156.2	206.3					
D30A		1020	920		174.2	230.0					
D30AP		1100	1000		202.9	267.9					
DE58A5	V12	1518	1380	57.2	261.3	345.0	A1-B5-A5-B3-A3-B6-A6-B2-A2-B4-A4-B1	2762x1582x2193	SAE00#21		
DE58A4		1672	1520		283.7	374.6					
DE58A3		1854	1685		308.5	407.2					
DE58A2		2002	1820		326.6	431.2					
DE58A1		2222	2020		358.9	473.7					
DE76A	V16	2970	2700	76.2	Testing in local market from 2021 to 2024 Sales to the global market from 2025						
DE95A	V20	3700	3360	95.3							

D Series Engine



CHARACTERIS

- High reliability
- Electronic speed
- Low noise/vibration
- Models of portable
- Low fuel consumption
- Emissions II

Model	Type	Rate Speed	Standby Power	Prime Power	Displacement	Fuel Consumption (L/h)		Firing Sequence	Size	Flywheel
		(r/min)	(kW)	(kW)		(L)	0.75		1.0	
D11B2	V6	1800	317	288	10.964	51.1	67.5	1-4-2-5-3-6	1251x1389x1288	SAE1#14
D11B1			340	318		57.9	76.5			
D11B			390	342		62.9	83.1			
D15B2	V8		405	370	14.618	66.4	87.7	1-5-7-2-6-3 -4-8	1661x1392x1307	
D15B1			460	405		73.4	96.9			
D15B			500	440		82.1	108.4			
D22B3	V12	577	525	21.927	93.7	123.8	1-12-5-8-3- 10-6-7-2-1 1-4-9	1995x1392x1312	SAE1#14	
D22B2		627	565		101.9	134.5				
D22B1		682	620		112.9	149.1				
D22B		739	671		114.1	150.6				
D22.2		790	718		133.4	176.1				
D22.1		832	756		142.5	188.1				
D30B4	V16	850	750	29.235	133.2	175.9	1-15-6-12- 8-5-16-7-1 1-4-9-2-14- 10-3-13	2340x1392x1360	SAE0#18	
D30B3		910	825		146.6	193.5				
D30B2		965	880		162.7	214.8				
D30B1		1020	920		180.0	237.7				
D30BP		1100	1000		205.6	271.4				

D Series Engine



RATINGS DEFINITION

The power ratings of Emergency Standby and Prime are in accordance with the standard of ISO8528. Fuel Stop power in accordance with the standard of ISO3046.

Electric power (kW) should be estimated by considering generator efficiency, cooling fan power loss and power derating based on altitude and temperature.

STANDBY POWER RATING is applicable for supplying emergency power for the duration of the utility power outage. No overload capability is available for this rating. A standby rated engine should be sized for a maximum of 70% average load factor and 200 hours of operation per year, this includes less than 25 hours per year at the Standby Power rating.

PRIME POWER RATING is available for an unlimited of hours per year in variable load application. Variable load should not exceed 70% average the Prime Power rating during any operating period hours., The total operating time at 100% Prime Power shall not exceed 500 hours per year.

10% overload capability is available for a period of 1 hour within a 12 hours period of operation. Total operating time at the 10% overload power shall not exceed 25 hours per year,

CONTINUOUS POWER RATING is the power that the engine can continue to use under the prescribed speed and the specific environment condition in the normal maintenance period stipulated in the manufacturing plant. Continuous power applicable for supplying utility power at a constant 100% for an unlimited number of hours per year. No overload capability is available for this rating.

D11 Series Engine



Ratings (kW)	1500rpm / 50Hz			
	D11	D11A	D11A1	D11A2
Prime	330	285	265	240
Standby	360	314	292	264
Continuous	252	220	204	185

Ratings (kW)	1800rpm / 60Hz		
	D11B	D11B1	D11B2
Prime	342	318	288
Standby	390	462	317
Continuous	273	323	222

GENERAL ENGINE DATA

Engine Model	D11	D11A	D11A1	D11A2	D11B	D11B1	D11B2
Engine Type	4-Cycle, V-type, 6-Cylinder, Turbo charged & inter-cooled (air to air)						
Speed	1500 rpm			1800 rpm			
Bore x stroke	128 x 142 mm						
Displacement	10.964 L						
Compression ratio	15 : 1	15.5 : 1		15 : 1		15.5 : 1	
Rotation {Looking at flywheel}	Counter clockwise {CCW}						
Firing order	1-4-2-5-3-6						
Injection timing	18°±1° BTDC @ 1500 rpm			20°±1° BTDC @ 1800 rpm			
Dry weight {W/O cooling system}	904 kg						
Dimension {L x W x H}	1251x1389x1288 mm						
Flywheel housing	SAE 1						
Flywheel	14{PCD:438.15mm/17.25inch}						
Number of teeth on flywheel	160						
Piston speed	7.1 m/s			8.52 m/s			

D11 Series Engine

INTAKE & EXHAUST SYSTEM

Engine Model	D11	D11A	D11A1	D11A2	D11B	D11B1	D11B2
Max.Intake Restriction (kPa)	5						
Max.Exhaust Back Pressure (kPa)	<10						
Combustion Air Consumption (m ³ /h)	2119	1820	1675	1507	2365	2042	1857
Max.Exhaust Temp.(After Turbo°C)	475	460	445	435	535	510	480
Exhaust Gas Flow (m ³ /h)	4885	4112	3707	3288	5890	5476	4960
Cooling fan air flow (m ³ /min)	675	675	675	675	810	810	810

ENGINE DATA WITH DRY EXHAUST MANIFOLD (STANDBY POWER)

Engine Model	D11	D11A	D11A1	D11A2	D11B	D11B1	D11B2
Cooling Water Circulation	320 L/min (1500 rpm)				390L/min (1800 rpm)		
Heat Rejection to Exhaust (kW)	278	242	219	197	314	266	246
Heat Rejection to Coolant (kW)	121	106	95	86	137	116	107
Heat Rejection to Intercooler (kW)	81	70	64	57	91	77	71
Radiated Heat to Ambient (kW)	37	32	21	18	60	41	35

ENGINE DATA WITH DRY EXHAUST MANIFOLD (PRIME POWER)

Engine Model	D11	D11A	D11A1	D11A2	D11B	D11B1	D11B2
Cooling Water Circulation	320 L/min (1500 rpm)				390L/min (1800 rpm)		
Heat Rejection to Exhaust (kW)	252	220	199	179	276	249	223
Heat Rejection to Coolant (kW)	110	96	87	78	120	109	97
Heat Rejection to Intercooler (kW)	73	64	58	52	80	72	65
Radiated Heat to Ambient (kW)	34	29	19	17	52	38	32

LUBRICATION SYSTEM

Force-feed lubrication by gear pump, lubricating oil cooling water circuit of engine

Lub.Method	Fully forced pressure feed type
Oil filter	Full flow, cartridge type
Lube oil specification	CF-4
Lube oil pressure	Idle Speed : Min 160 kPa Governed Speed: Min 200 kPa
Maximum oil temperature	110 °C
Max.Permissible Oil Temperature	90 °C
Oil Consumption (as % of fuel consumption)	≤0.5
Oil capacity	25 L

D11 Series Engine

COOLING SYSTEM

Water circulation by centrifugal pump on engine

Cooling method	Fresh water forced circulation
Coolant capacity	Engine 19L + Radiator 70L
Coolant flow rate	320 liters / min @1800 rpm, 390 liters / min @1500 rpm
Pressure Cap	49 kPa
Max.Permissible Temperature	90 °C
Max.Coolant warning Temperature	95 °C
Max.Coolant Shutdown Temperature	105 °C
Thermostat Open Temperature	71 °C
Max.external coolant system restriction	Not available

Two radiator options are provided, based on allowable maximum Air temperature On radiator inlet (Air On 40 °C) Air On 50 °C

- ATB (Ambient Temperature before Boiling) of generator set varies depending on the engine room ventilation design, even if the same radiator applied. Adequate selection of radiator options by means of the cooling test is highly recommended, and generator set makers are responsible for the selection.

AIR INDUCTION SYSTEM

Engine Model	D11	D11A	D11A1	D11A2	D11B	D11B1	D11B2
Maximum Intake Air Restriction							
- With Clean Filter Element (m³/h)	2119	1820	1675	1507	2365	2042	1857
- With Dirty Filter Element (m³/h)	6103	5242	4824	4340	6811	5881	5348
Max.static pressure after radiator (Pa)	955 Pa						

FUEL SYSTEM

In-line pump with integrated, electromagnetic actuator

Engine Model	D11	D11A	D11A1	D11A2	D11B	D11B1	D11B2
Governor	Electric type (Original GAC from USA)						
Speed drop	G2 Class (ISO 8528)						
Feed pump	Mechanical type in pump						
Injection nozzle	Multi hole type						
Opening pressure	28 MPa						
Fuel filter	Full flow, Cartridge type with water drain valve						
Maximum fuel inlet restriction	30 kPa						
Maximum fuel return restriction	60 kPa						
Fuel feed pump Capacity	226 L/h						
Fuel	Diesel fuel						
Fuel consumption							
Standby power- 100% load (L/h)	84.7	72.0	66.3	59.7	90.4	83.3	73.6
Prime Power - 100% load (L/h)	77.8	66.2	60.9	54.9	83.1	76.5	67.5
- 75% load (L/h)	58.9	50.1	46.1	41.6	62.9	57.9	51.2
- 50% load (L/h)	39.7	33.7	31.1	28.0	42.4	39.0	34.4
- 25% load (L/h)	20.0	17.0	15.7	14.1	21.4	19.7	17.4
Continuous power - 100% load (L/h)	59.4	51.0	47.0	42.2	66.3	77.8	52.0
Fuel Consumption Ratio (g/kW.h)	198	195	193	192	204	202	197

D11 Series Engine

ELECTRICAL SYSTEM

Charging Alternator Voltage	28V
Charging Alternator Capacity	45A
Voltage regulator	Built-in type IC regulator
Starting motor	7kW
Battery Voltage	24V
Battery Capacity	2 x 200 Ah (recommended)
Starting aid (Option)	Block heater (Min. Temperature for Unaided Cold Start -10°C)

VALVE SYSTEM

Type	Overhead valve type	
Number of valve	Intake 1, exhaust 1 per cylinder	
Valve lashes at cold	Intake 0.3 mm, Exhaust 0.4 mm	
Valve timing	Opening	Close
- Intake valve	24 deg.BTDC	36 deg.ABDC
- Exhaust valve	63 deg.BBDC	27 deg.ATDC

D11 (V6) SERIES DIESEL ENGINE DRAWING

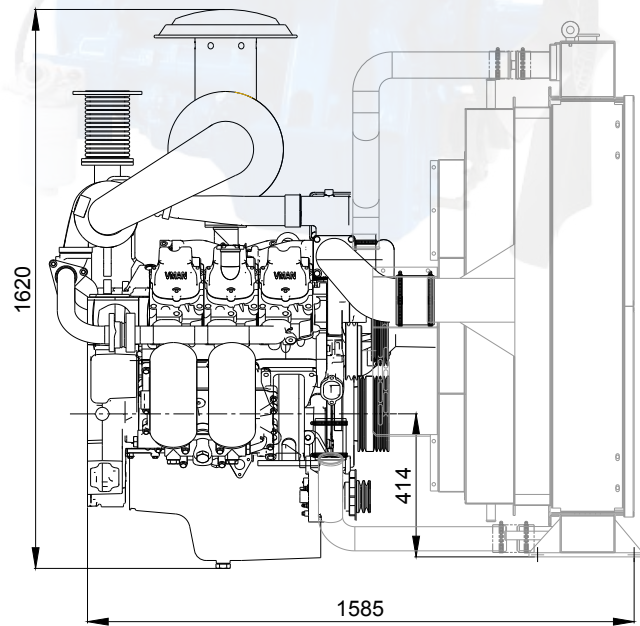
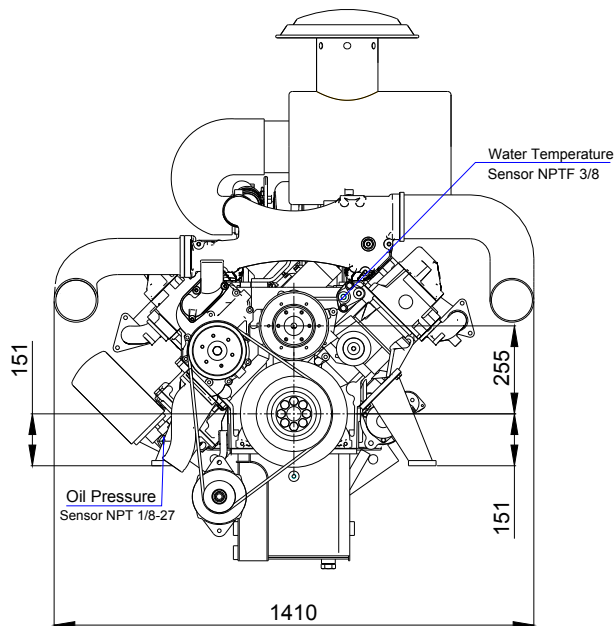

D15 Series Engine



Ratings (kW)	1500rpm / 50Hz			
	D15	D15A	D15A1	D15A2
Prime	450	405	365	330
Standby	500	445	415	363
Continuous	350	312	291	254

Ratings (kW)	1800rpm / 60Hz		
	D15B	D15B1	D15B2
Prime	440	405	370
Standby	500	460	405
Continuous	350	322	284

GENERAL ENGINE DATA

Engine Model	D15	D15A	D15A1	D15A2	D15B	D15B1	D15B2
Engine Type	4-Cycle, V-type, 8-Cylinder, Turbo charged & inter-cooled (air to air)						
Speed	1500 rpm			1800 rpm			
Bore x stroke	128 x 142 mm						
Displacement	14.618 L						
Compression ratio	15 : 1	15.5 : 1			15 : 1	15.5 : 1	
Rotation {Looking at flywheel}	Counter clockwise {CCW}						
Firing order	1-5-7-2-6-3-4-8						
Injection timing	18°±1° BTDC @ 1500 rpm			20°±1° BTDC @ 1800 rpm			
Dry weight {W/O cooling system}	1050 kg						
Dimension {L x W x H}	1661 x 1392 x 1307 mm						
Flywheel housing	SAE 1						
Flywheel	14{PCD:438.15mm/17.25inch}						
Number of teeth on flywheel	160						
Piston speed	7.1 m/s			8.82 m/s			

D15 Series Engine

INTAKE & EXHAUST SYSTEM

Engine Model	D15	D15A	D15A1	D15A2	D15B	D15B1	D15B2
Max.Intake Restriction (kPa)					5		
Max.Exhaust Back Pressure (kPa)					<10		
Combustion Air Consumption (m ³ /h)	3047	2699	2418	2137	3077	2749	2396
Max.Exhaust Temp.(After Turbo°C)	520	510	493	440	530	500	465
Exhaust Gas Flow (m ³ /h)	7447	6512	5709	4695	7615	6548	5449
Cooling fan air flow (m ³ /min)	713	713	675	675	810	810	810

ENGINE DATA WITH DRY EXHAUST MANIFOLD (STANDBY POWER)

Engine Model	D15	D15A	D15A1	D15A2	D15B	D15B1	D15B2
Cooling Water Circulation	590 L/min (1500 rpm)				660L/min (1800 rpm)		
Heat Rejection to Exhaust (kW)	396	353	319	276	411	358	318
Heat Rejection to Coolant (kW)	173	154	139	120	179	156	138
Heat Rejection to Intercooler (kW)	115	102	93	80	119	104	92
Radiated Heat to Ambient (kW)	63	56	51	44	66	57	51

ENGINE DATA WITH DRY EXHAUST MANIFOLD (PRIME POWER)

Engine Model	D15	D15A	D15A1	D15A2	D15B	D15B1	D15B2
Cooling Water Circulation	590 L/min (1500 rpm)				660L/min (1800 rpm)		
Heat Rejection to Exhaust (kW)	361	321	280	251	361	316	290
Heat Rejection to Coolant (kW)	157	140	122	109	157	138	126
Heat Rejection to Intercooler (kW)	105	93	81	73	105	92	84
Radiated Heat to Ambient (kW)	58	51	45	40	58	50	46

LUBRICATION SYSTEM

Force-feed lubrication by gear pump, lubricating oil cooling water circuit of engine

Lub.Method	Fully forced pressure feed type
Oil filter	Full flow, cartridge type
Lube oil specification	CF-4
Lube oil pressure	Idle Speed : Min 160 kPa Governed Speed: Min 200 kPa
Maximum oil temperature	110 °C
Max.Permissible Oil Temperature	90 °C
Oil Consumption (as % of fuel consumption)	≤0.5
Oil capacity	27 L

D15 Series Engine

COOLING SYSTEM

Water circulation by centrifugal pump on engine

Cooling method	Fresh water forced circulation
Coolant capacity	Engine 20L + Radiator 75L
Coolant flow rate	660 liters / min @1800 rpm, 590 liters / min @1500 rpm
Pressure Cap	49 kPa
Coolant Capacity for Engine	20 L
Max.Permissible Temperature	90 °C
Max.Coolant warning Temperature	95 °C
Max.Coolant Shutdown Temperature	105 °C
Thermostat Open Temperature	71 °C
Max.external coolant system restriction	Not available

Two radiator options are provided, based on allowable maximum Air temperature On radiator inlet (Air On 40 °C) Air On 50 °C

- ATB (Ambient Temperature before Boiling) of generator set varies depending on the engine room ventilation design, even if the same radiator applied. Adequate selection of radiator options by means of the cooling test is highly recommended, and generator set makers are responsible for the selection.

AIR INDUCTION SYSTEM

Engine Model	D15	D15A	D15A1	D15A2	D15B	D15B1	D15B2
Maximum Intake Air Restriction							
- With Clean Filter Element (m³/h)	3047	2697	2418	2137	3077	2749	2396
- With Dirty Filter Element (m³/h)	8775	7767	6964	6155	8862	7917	6900
Max.static pressure after radiator (Pa)	1126 Pa @ 1500rpm				955 Pa @ 1500rpm		

FUEL SYSTEM

In-line pump with integrated, electromagnetic actuator

Engine Model	D15	D15A	D15A1	D15A2	D15B	D15B1	D15B2
Governor	Electric type (Original GAC from USA)						
Speed drop	G2 Class (ISO 8528)						
Feed pump	Mechanical type in pump						
Injection nozzle	Multi hole type						
Opening pressure	28 MPa						
Fuel filter	Full flow, Cartridge type with water drain valve						
Maximum fuel inlet restriction	30 kPa						
Maximum fuel return restriction	60 kPa						
Fuel feed pump Capacity	315 L/h						
Fuel	Diesel fuel						
Fuel consumption							
Standby power- 100% load (L/h)	119.6	107.1	92.7	84.7	118.1	105.5	95.5
Prime Power - 100% load (L/h)	109.8	98.4	85.2	77.8	108.4	96.9	87.7
- 75% load (L/h)	83.2	74.5	64.5	58.9	82.1	73.4	66.4
- 50% load (L/h)	56.0	50.2	43.4	39.7	55.3	49.4	44.7
- 25% load (L/h)	28.3	25.3	21.9	20.0	27.9	25.0	22.6
Continuous power - 100% load (L/h)	85.4	75.7	67.8	59.9	86.3	77.1	67.2
Fuel Consumption Ratio (g/kWh)	205	204	196	198	207	201	199

D15 Series Engine

ELECTRICAL SYSTEM

Charging Alternator Voltage	28V
Charging Alternator Capacity	45A
Voltage regulator	Built-in type IC regulator
Starting motor	7kW
Battery Voltage	24V
Battery Capacity	2 x 200 Ah (recommended)
Starting aid (Option)	Block heater (Min. Temperature for Unaided Cold Start -10°C)

VALVE SYSTEM

Type	Overhead valve type	
Number of valve	Intake 1, exhaust 1 per cylinder	
Valve lashes at cold	Intake 0.3 mm, Exhaust 0.4 mm	
Valve timing	Opening	Close
- Intake valve	24 deg.BTDC	36 deg.ABDC
- Exhaust valve	63 deg.BBDC	27 deg.ATDC

D15 (V8) SERIES DIESEL ENGINE DRAWING

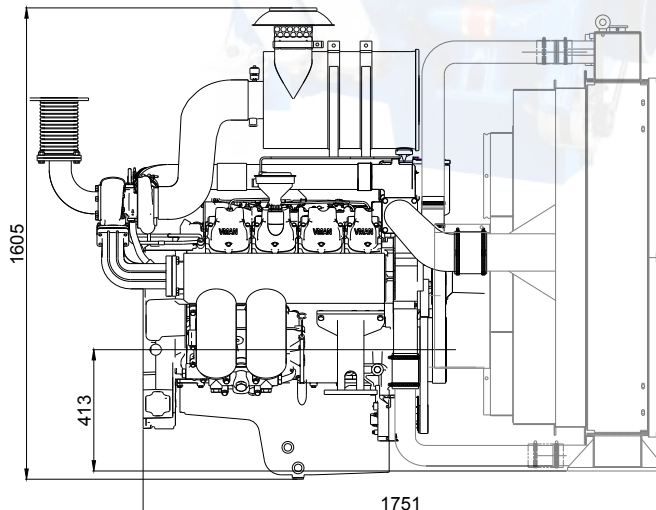
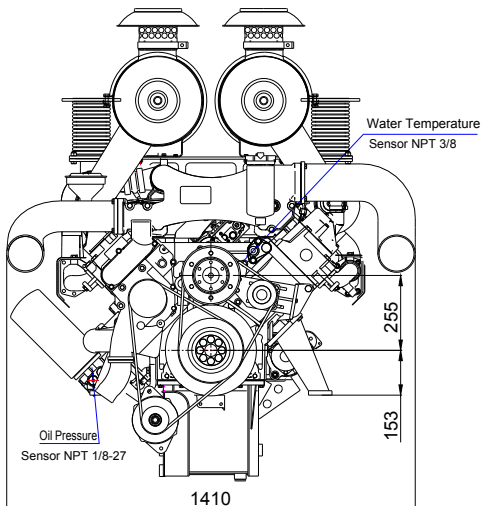

D22 Series Engine



Ratings (kW)	1500rpm / 50Hz				
	D22Z	D22	D22A	D22A2	D22A3
Prime	660	630	555	515	455
Standby	735	700	606	565	505
Continuous	515	490	424	396	354

Ratings (kW)	1800rpm / 60Hz					
	D22.1	D22.2	D22B	D22B1	D22B2	D22B3
Prime	756	718	617	620	565	525
Standby	832	790	739	682	627	577
Continuous	582	553	517	477	439	404

GENERAL ENGINE DATA

Engine Model	D22Z	D22	D22A	D22A2	D22A3	D22.1	D22.2	D22B	D22B1	D22B2	D22B3
Engine Type	4-Cycle, V-type, 12-Cylinder, Turbo charged & inter-cooled (air to air)										
Speed	1500 rpm					1800 rpm					
Bore x stroke	128 x 142 mm										
Displacement	21.927 L										
Compression ratio	15 : 1	15.5 : 1			15 : 1		15.5 : 1				
Rotation {Looking at flywheel}	Counter clockwise {CCW}										
Firing order	1-12-5-8-3-10-6-7-2-11-4-9										
Injection timing	18°±1° BTDC @ 1500 rpm					20°±1° BTDC @ 1800 rpm					
Dry weight {W/O cooling system}	1575 kg										
Dimension {L x W x H}	1995 x 1392 x 1312 mm										
Flywheel housing	SAE 1 or SAE 0										
Flywheel	14{PCD:438.15mm/17.25inch} or 18{PCD:543mm/31.38inch}										
Number of teeth on flywheel	160										
Piston speed	7.1 m/s					8.52 m/s					

D22 Series Engine

INTAKE & EXHAUST SYSTEM

Engine Model	D22Z	D22	D22A	D22A2	D22A3	D22.1	D22.2	D22B	D22B1	D22B2	D22B3
Max.Intake Restriction (kPa)	5										
Max.Exhaust Back Pressure (kPa)	<10										
Combustion Air Consumption (m ³ /h)	4480	4204	3477	3309	2958	5710	4838	4504	4096	3728	3396
Max.Exhaust Temp.(After Turbo°C)	550	550	540	513	502	550	545	540	525	510	480
Exhaust Gas Flow (m ³ /h)	11361	10662	8712	8015	7064	13112	12197	11284	10072	8996	7882
Cooling fan air flow (m ³ /min)	863	863	750	720	720	1100	950	950	950	950	950

ENGINE DATA WITH DRY EXHAUST MANIFOLD (STANDBY POWER)

Engine Model	D22Z	D22	D22A	D22A2	D22A3	D22.1	D22.2	D22B	D22B1	D22B2	D22B3
Cooling Water Circulation	590 L/min @ 1500 rpm					660 L/min @ 1800 rpm					
Heat Rejection to Exhaust (kW)	578	551	475	431	378	684	646	604	548	493	452
Heat Rejection to Coolant (kW)	252	240	207	188	165	298	282	263	239	215	197
Heat Rejection to Intercooler (kW)	168	160	138	125	110	199	188	175	159	143	131
Radiated Heat to Ambient (kW)	92	88	76	69	60	109	103	97	88	79	72

ENGINE DATA WITH DRY EXHAUST MANIFOLD (PRIME POWER)

Engine Model	D22Z	D22	D22A	D22A2	D22A3	D22.1	D22.2	D22B	D22B1	D22B2	D22B3
Cooling Water Circulation	590 L/min @1500rpm					660 L/min @1800rpm					
Heat Rejection to Exhaust (kW)	526	496	435	393	341	621	587	549	498	444	411
Heat Rejection to Coolant (kW)	229	216	189	171	149	271	256	239	217	194	179
Heat Rejection to Intercooler (kW)	153	144	126	114	99	180	170	159	145	129	119
Radiated Heat to Ambient (kW)	84	79	69	63	54	99	94	88	80	71	66

LUBRICATION SYSTEM

Force-feed lubrication by gear pump, lubricating oil cooling water circuit of engine

Lub.Method	Fully forced pressure feed type
Oil filter	Full flow, cartridge type
Lube oil specification	CF-4
Lube oil pressure	Idle Speed : Min 160 kPa Governed Speed: Min 200 kPa
Maximum oil temperature	110 °C
Max.Permissible Oil Temperature	90 °C
Oil Consumption (as % of fuel consumption)	≤0.5
Oil capacity	57 L

D22 Series Engine

COOLING SYSTEM

Water circulation by centrifugal pump on engine

Cooling method	Fresh water forced circulation
Coolant capacity	Engine 23L + Radiator 96L
Coolant flow rate	660 liters/min @1800rpm; 590 liters/min @1500rpm
Pressure Cap	49 kPa
Max.Permissible Temperature	90 °C
Max.Coolant warning Temperature	95 °C
Max.Coolant Shutdown Temperature	105 °C
Thermostat Open Temperature	71 °C
Max.external coolant system restriction	Not available

Two radiator options are provided, based on allowable maximum Air temperature On radiator inlet (Air On 40 °C) Air On 50 °C

- ATB (Ambient Temperature before Boiling) of generator set varies depending on the engine room ventilation design, even if the same radiator applied. Adequate selection of radiator options by means of the cooling test is highly recommended, and generator set makers are responsible for the selection.

AIR INDUCTION SYSTEM

Engine Model	D22Z	D22	D22A	D22A2	D22A3	D22.1	D22.2	D22B	D22B1	D22B2	D22B3
Maximum Intake Air Restriction											
- With Clean Filter Element (m³/h)	4480	4204	3477	3309	2958	5170	4838	4504	4096	3728	3396
- With Dirty Filter Element (m³/h)	12902	12108	10014	9530	8519	14890	13933	12972	11796	10737	9780
Max.static pressure after radiator (Pa)	662 Pa @1500rpm						733 Pa @1800rpm				

FUEL SYSTEM

In-line pump with integrated, electromagnetic actuator

Engine Model	D22Z	D22	D22A	D22A2	D22A3	D22.1	D22.2	D22B	D22B1	D22B2	D22B3
Governor	Electric type (Original GAC from USA)										
Speed drop	G2 Class (ISO 8528)										
Feed pump	Mechanical type in pump										
Injection nozzle	Multi hole type										
Opening pressure	28 MPa										
Fuel filter	Full flow, Cartridge type with water drain valve										
Maximum fuel inlet restriction	30 kPa										
Maximum fuel return restriction	60kPa										
Fuel feed pump Capacity	630 L/h										
Fuel	Diesel fuel										
Fuel consumption											
Standby power- 100% load (L/h)	175.4	165.0	138.9	131.5	116.2	204.8	191.8	164.0	162.4	146.5	134.8
Prime Power - 100% load (L/h)	161.1	151.5	127.5	120.8	106.7	188.1	176.1	150.6	149.1	134.5	123.8
- 75% load (L/h)	122.0	114.8	96.6	91.5	80.8	142.5	133.4	114.1	112.9	101.9	93.7
- 50% load (L/h)	82.1	77.3	65.0	61.6	54.4	95.9	89.8	76.8	76.0	68.6	63.1
- 25% load (L/h)	41.5	39.0	32.8	31.1	27.5	48.4	45.3	38.8	38.4	34.6	31.9
Continous power - 100% load (L/h)	125.6	117.8	97.5	92.8	82.9	144.9	135.6	126.2	114.8	104.5	95.2
Fuel Consumption Ratio (g/kW.h)	205	202	193	197	197	209	206	205	202	200	198

D22 Series Engine

ELECTRICAL SYSTEM

Charging Alternator Voltage	28V
Charging Alternator Capacity	45A
Voltage regulator	Built-in type IC regulator
Starting motor	9kW
Battery Voltage	24V
Battery Capacity	2 x 250 Ah (recommended)
Starting aid (Option)	Block heater (Min. Temperature for Unaided Cold Start -10°C)

VALVE SYSTEM

Type	Overhead valve type	
Number of valve	Intake 1, exhaust 1 per cylinder	
Valve lashes at cold	Intake 0.3 mm, Exhaust 0.4 mm	
Valve timing	Opening	Close
- Intake valve	24 deg.BTDC	36 deg.ABDC
- Exhaust valve	63 deg.BBDC	27 deg.ATDC

D22 (V12) SERIES DIESEL ENGINE DRAWING

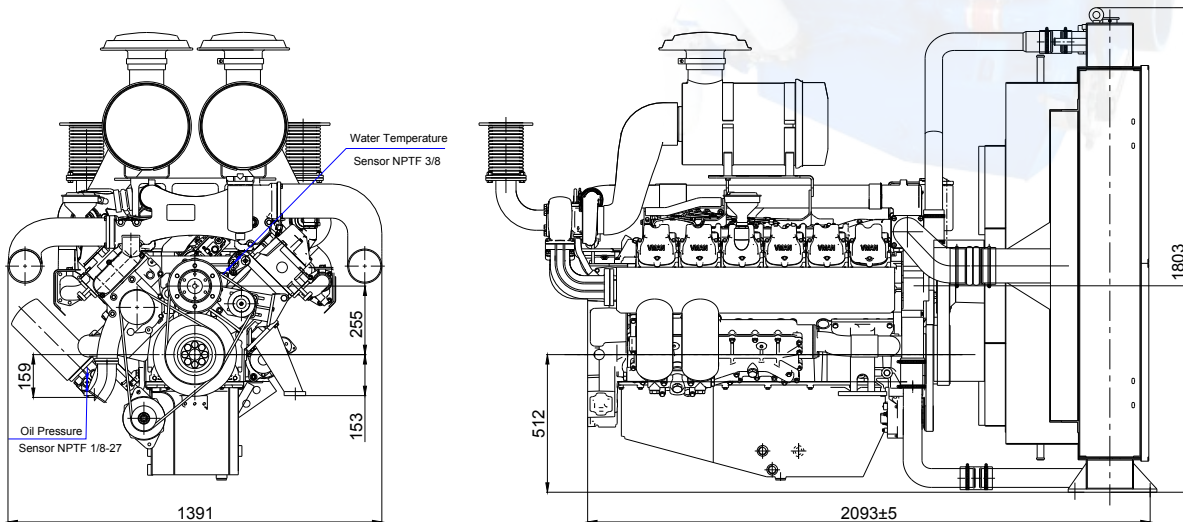

D30 Series Engine



Ratings (kW)	1500rpm / 50Hz				
	D30AP	D30A	D30A1	D30A2	D30A3
Prime	1000	920	875	795	705
Standby	1100	1020	960	880	780
Continuous	770	714	672	616	546

Ratings (kW)	1800rpm / 60Hz				
	D30BP	D30B1	D30B2	D30B3	D30B4
Prime	1000	920	880	825	750
Standby	1100	1020	965	910	850
Continuous	770	714	676	637	595

GENERAL ENGINE DATA

Engine Model	D30AP	D30A	D30A1	D30A2	D30A3	D30BP	D30B1	D30B2	D30B3	D30B4
Engine Type	4-Cycle, V-type, 16-Cylinder, Turbo charged & inter-cooled (air to air)									
Speed	1500 rpm					1800 rpm				
Bore x stroke	128 x 142 mm									
Displacement	29.235 L									
Compression ratio	14.6 : 1		15.5 : 1			14.6 : 1		15.5 : 1		
Rotation {Looking at flywheel}	Counter clockwise {CCW}									
Firing order	1-15-6-12-8-5-16-7-11-4-9-2-14-10-3-13									
Injection timing	18°±1° BTDC @ 1500 rpm					20°±1° BTDC @ 1800 rpm				
Dry weight {W/O cooling system}	2100 kg									
Dimension {L x W x H}	2340 x 1392 x 1360 mm									
Flywheel housing	SAE 0									
Flywheel	18{PCD:543mm/31.38inch}									
Number of teeth on flywheel	160									
Piston speed	7.1 m/s					8.52 m/s				

D30 Series Engine

INTAKE & EXHAUST SYSTEM

Engine Model	D30AP	D30A	D30A1	D30A2	D30A3	D30BP	D30B1	D30B2	D30B3	D30B4
Max.Intake Restriction (kPa)						5				
Max.Exhaust Back Pressure (kPa)						10				
Combustion Air Consumption (m ³ /h)	7115	6368	5651	5154	4591	7351	6580	5881	5330	4978
Max.Exhaust Temp.(After Turbo°C)	518	510	500	487	473	665	540	506	480	475
Exhaust Gas Flow (m ³ /h)	17461	15366	13462	12071	10556	18735	16487	14119	12368	11476
Cooling fan air flow (m ³ /min)	1755	1755	1755	1755	1365	1750	1750	1750	1400	1400

Engine Data with Dry Exhaust Manifold (Standby Power)

Engine Model	D30AP	D30A	D30A1	D30A2	D30A3	D30BP	D30B1	D30B2	D30B3	D30B4
Cooling Water Circulation	866 L/min (1500 rpm)					1040L/min (1800 rpm)				
Heat Rejection to Exhaust (kW)	898	839	773	701	614	916	856	782	685	644
Heat Rejection to Coolant (kW)	392	366	337	306	268	399	373	341	298	281
Heat Rejection to Intercooler (kW)	261	244	225	204	178	266	249	227	199	187
Radiated Heat to Ambient (kW)	143	134	124	112	98	147	137	125	109	103

Engine Data with Dry Exhaust Manifold (Prime Power)

Engine Model	D30AP	D30A	D30A1	D30A2	D30A3	D30BP	D30B1	D30B2	D30B3	D30B4
Cooling Water Circulation	866 L/min (1500 rpm)					1040L/min (1800 rpm)				
Heat Rejection to Exhaust (kW)	815	762	705	633	555	835	780	713	621	568
Heat Rejection to Coolant (kW)	355	332	307	276	242	364	340	311	271	248
Heat Rejection to Intercooler (kW)	236	221	205	184	161	243	227	207	180	165
Radiated Heat to Ambient (kW)	131	122	113	101	89	134	125	114	99	91

LUBRICATION SYSTEM

Force-feed lubrication by gear pump, lubricating oil cooling water circuit of engine

Lub.Method	Fully forced pressure feed type
Oil filter	Full flow, cartridge type
Lube oil specification	CF-4
Lube oil pressure	Idle Speed : Min 160 kPa Governed Speed: Min 200 kPa
Maximum oil temperature	110 °C
Max.Permissible Oil Temperature	90 °C
Oil Consumption (as % of fuel consumption)	≤0.5
Oil capacity	78 L

D30 Series Engine

COOLING SYSTEM

Water circulation by centrifugal pump on engine

Cooling method	Fresh water forced circulation
Coolant capacity	Engine 26L + Radiator 125L
Coolant flow rate	1040 liters / min @1800 rpm, 860 liters / min @1500 rpm
Pressure Cap	49 kPa
Coolant Capacity for Engine	26 L
Max.Permissible Temperature	90 °C
Max.Coolant warning Temperature	95 °C
Max.Coolant Shutdown Temperature	105 °C
Thermostat Open Temperature	71 °C
Max.external coolant system restriction	Not available

Two radiator options are provided, based on allowable maximum Air temperature On radiator inlet (Air On 40 °C) Air On 50 °C

- ATB (Ambient Temperature before Boiling) of generator set varies depending on the engine room ventilation design, even if the same radiator applied. Adequate selection of radiator options by means of the cooling test is highly recommended, and generator set makers are responsible for the selection.

AIR INDUCTION SYSTEM

Engine Model	D30AP	D30A	D30A1	D30A2	D30A3	D30B0	D30B1	D30B2	D30B3	D30B4
Maximum Intake Air Restriction										
- With Clean Filter Element (m³/h)	7115	6368	5651	5154	4591	7351	6580	5881	5330	4978
- With Dirty Filter Element (m³/h)	20491	18340	16275	14844	13222	21171	18950	16937	15350	14337
Max.static pressure after radiator (Pa)	1500 Pa @1500rpm					3000 Pa @1800rpm				

FUEL SYSTEM

In-line pump with integrated, electromagnetic actuator

Engine Model	D30AP	D30A	D30A1	D30A2	D30A3	D30BP	D30B1	D30B2	D30B3	D30B4
Governor	Electric type (HEINZMANN Speed governor)									
Speed drop	G2 Class (ISO 8528)									
Feed pump	Mechanical type in injpump									
Injection nozzle	Multi hole type									
Opening pressure	28 MPa									
Fuel filter	Full flow, Cartridge type with water drain valve									
Maximum fuel inlet restriction	30 kPa									
Maximum fuel return restriction	60 kPa									
Fuel feed pump Capacity	739 L/h									
Fuel	Diesel fuel									
Fuel consumption										
Standby power- 100% load (L/h)	291.7	250.5	224.6	203.0	181.0	295.6	258.8	233.9	210.7	191.5
Prime Power - 100% load (L/h)	267.9	230.0	206.3	186.4	166.2	271.4	237.7	214.8	193.5	175.9
- 75% load (L/h)	202.9	174.2	156.2	141.2	125.9	205.6	180.0	162.7	146.6	133.2
- 50% load (L/h)	136.6	117.3	105.2	95.1	84.8	138.4	121.2	109.5	98.7	89.7
- 25% load (L/h)	69.0	59.2	53.1	48.0	42.8	69.9	61.2	55.3	49.8	45.3
Continous power - 100% load (L/h)	206.3	178.5	158.4	144.5	128.7	209.0	184.5	164.9	149.4	139.5
Fuel Consumption Ratio (g/kW.h)	225	210	198	197	198	228	217	205	197	197

D30 Series Engine

ELECTRICAL SYSTEM

Charging Alternator Voltage	28V
Charging Alternator Capacity	45A
Voltage regulator	Built-in type IC regulator
Starting motor	11kW
Battery Voltage	24V
Battery Capacity	2 x 250 Ah (recommended)
Starting aid (Option)	Block heater (Min. Temperature for Unaided Cold Start -10°C)

VALVE SYSTEM

Type	Overhead valve type	
Number of valve	Intake 1, exhaust 1 per cylinder	
Valve lashes at cold	Intake 0.3 mm, Exhaust 0.4 mm	
Valve timing	Opening	Close
- Intake valve	24 deg.BTDC	36 deg.ABDC
- Exhaust valve	63 deg.BBDC	27 deg.ATDC

D30 (V16) SERIES DIESEL ENGINE DRAWING

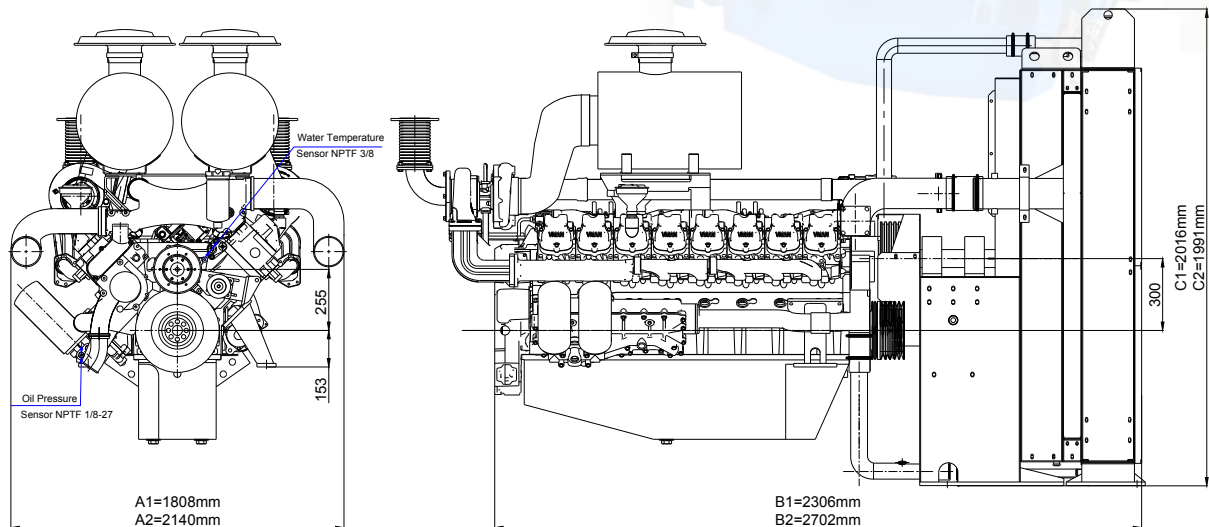

The size of A1 B1 C1 for D30A3 & D30B4

The size of A2 B2 C2 for D30AP D30A D30A1 D30A2 & D30BP D30B1 D30B2 D30B3

DE11 Series Engine



Ratings (kW)	1500rpm / 50Hz		
	DE11A420	DE11A400	DE11A360
Prime	285	265	240
Standby	310	292	265
Continuous	217	201	182

Ratings (kW)	1800rpm / 60Hz		
	DE11B540	DE11B470	DE11B430
Prime	358	318	288
Standby	400	348	318
Continuous	272	242	219

GENERAL ENGINE DATA

Engine Model	DE11A420	DE11A400	DE11A360	DE11B540	DE11B470	DE11B430
Engine Type	4-Cycle, V-type, 6-Cylinder, Turbo charger & intercooler (air to air)					
Speed	1500rpm			1800rpm		
Bore x stroke	128 * 142 mm					
Displacement	10.964 L					
Compression ratio	14.6 : 1	15.5 : 1		14.6 : 4	15.5 : 1	
Rotation {Looking at flywheel}	Counter clockwise {CCW}					
Firing order	1-4-2-5-3-6					
Injection timing	18°±1° BTDC @ 1500 rpm			20°±1° BTDC @ 1800 rpm		
Dry weight {W/O cooling system}	904 kg					
Dimension {L x W x H}	1251*1389*1288 mm					
Flywheel housing	SAE 1					
Flywheel	14{PCD:438.15mm/17.25inch}					
Number of teeth on flywheel	160					
Piston speed	200 m/s			240 m/s		
ENGINE MOUNTING						
Max.Bending Moment at Rear Face to Block	1325 N.m					

DE11 Series Engine

COOLING SYSTEM

Water circulation by centrifugal pump on engine

Cooling method	Fresh water forced circulation
Coolant capacity	Engine 19L + Radiator 70L
Coolant flow rate	320 liters/min @1500rpm, 390 liters/min @1800rpm
Pressure Cap	49 kPa
Coolant Capacity for Engine	19 L
Max.Permissible Temperature	90 °C
Max.Coolant warning Temperature	95 °C
Max.Coolant Shutdown Temperature	105 °C
Thermostat Open Temperature	71 °C
Max.external coolant system restriction	Not available

Two radiator options are provided, based on allowable maximum Air temperature On radiator inlet (Air On 40 °C Air On 50 °C

- ATB (Ambient Temperature before Boiling) of generator set varies depending on the engine room ventilation design, even if the same radiator applied. Adequate selection of radiator options by means of the cooling test is highly recommended, and generator set makers are responsible for the selection.

AIR INDUCTION SYSTEM

Engine Model	DE11A420	DE11A400	DE11A360	DE11B540	DE11B470	DE11B430
Maximum Intake Air Restriction						
- With Clean Filter Element (m³/h)	1779	1667	1505	2402	2069	1853
- With Dirty Filter Element (m³/h)	6103	5242	4334	6918	5959	5337
Max.static pressure after radiator (Pa)	955 Pa					

FUEL SYSTEM

High pressure common rail

Engine Model	DE11A420	DE11A400	DE11A360	DE11B540	DE11B470	DE11B430
Governor	ECU					
Speed drop	G2 Class (ISO 8528)					
Feed pump	Mechanical type in injpump					
Injection nozzle	Multi hole type					
Opening pressure	28 MPa					
Fuel filter	Full flow, Cartridge type with water drain valve					
Maximum fuel inlet restriction	30 kPa					
Maximum fuel return restriction	60 kPa					
Fuel feed pump Capacity	226 L/h					
Fuel	Diesel fuel					
Fuel consumption						
Standby power- 100% load (L/h)	75.7	69.7	63.1	102.2	86.8	78.6
Prime Power - 100% load (L/h)	68.2	63.1	56.8	87.0	79.0	70.5
- 75% load (L/h)	51.0	47.0	41.7	64.0	58.7	51.3
- 50% load (L/h)	34.2	32.9	29.7	44.0	39.9	36.0
- 25% load (L/h)	21.0	19.2	17.5	25.0	23.2	20.8
Continous power - 100% load (L/h)	51.0	47.3	42.1	64.0	59.0	51.0
Fuel Consumption Ratio (g/kW.h)	192-204 g/kW.h					

DE11 Series Engine

LUBRICATION SYSTEM

Force-feed lubrication by gear pump, lubricating oil cooling water circuit of engine

Lub.Method	Fully forced pressure feed type
Oil filter	Full flow, cartridge type
Lube oil specification	CF-4
Lube oil pressure	Idle Speed : Min 160 kPa Governed Speed: Min 200 kPa
Maximum oil temperature	110 °C
Max.Permissible Oil Temperature	90 °C
Oil Consumption (as % of fuel consumption)	≤0.5
Oil Capacity	25 L

ELECTRICAL SYSTEM

Charging Alternator Voltage	28V
Charging Alternator Capacity	45A
Voltage regulator	Built-in type IC regulator
Starting motor	7kW
Battery Voltage	24V
Battery Capacity	2 * 200 Ah (recommended)
Starting aid (Option)	Block heater (Min. Temperature for Unaided Cold Start -10°C)

VALVE SYSTEM

Type	Overhead valve type	
Number of valve	Intake 1, exhaust 1 per cylinder	
Valve lashes at cold	Intake 0.3 mm, Exhaust 0.4 mm	
Valve timing		
	Opening	Close
- Intake valve	24 deg.BTDC	36 deg.ABDC
- Exhaust valve	63 deg.BBDC	27 deg.ATDC

Engine Data with Dry Exhaust Manifold (Standby Power)

Engine Model	DE11A420	DE11A400	DE11A360	DE11B540	DE11B470	DE11B430
Cooling Water Circulation	320 L/min @1500rpm			390L/min @1800rpm		
Heat Rejection to Exhaust (kW)	242	219	197	314	266	246
Heat Rejection to Coolant (kW)	106	95	86	137	116	107
Heat Rejection to Intercooler (kW)	70	64	57	91	77	71
Radiated Heat to Ambient (kW)	32	21	18	60	41	35

DE11 Series Engine

Engine Data with Dry Exhaust Manifold (Prime Power)

Engine Model	DE11A420	DE11A400	DE11A360	DE11B540	DE11B470	DE11B430
Cooling Water Circulation	320 L/min @1500rpm			390L/min @1800rpm		
Heat Rejection to Exhaust (kW)	218	197	177	283	239	221
Heat Rejection to Coolant (kW)	95	86	77	123	104	96
Heat Rejection to Intercooler (kW)	63	58	51	82	69	64
Radiated Heat to Ambient (kW)	29	19	16	54	37	32

DE11 (V6) SERIES T3 DIESEL ENGINE DRAWING

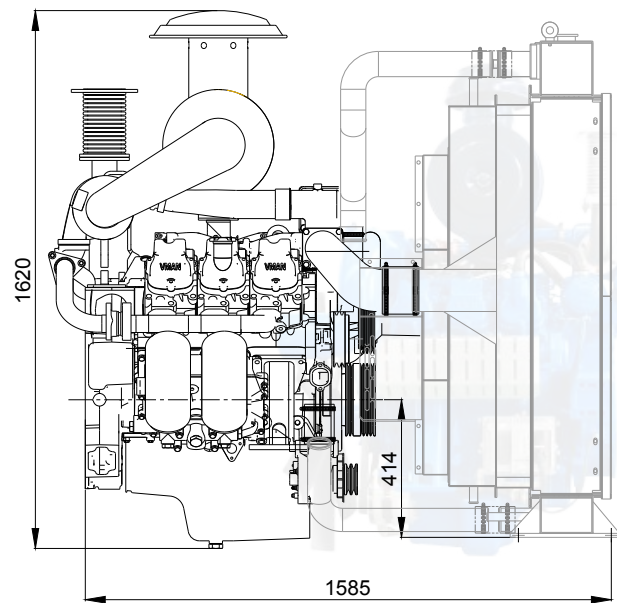
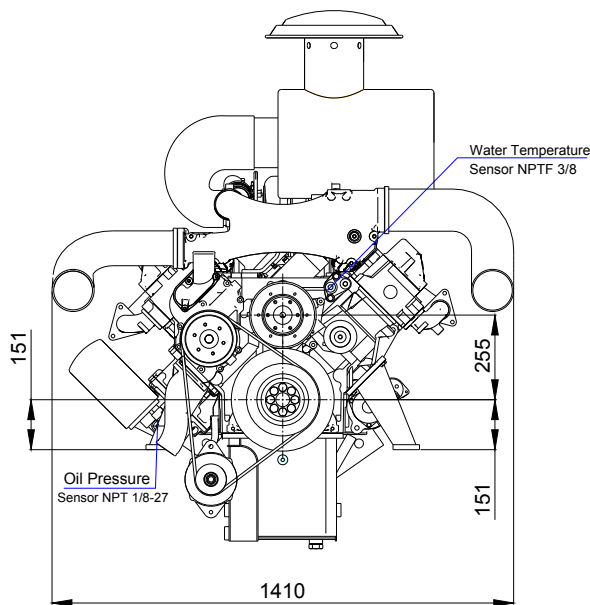

DE15 Series Engine



Ratings (kW)	1500rpm / 50Hz			
	DE15A660	DE15A610	DE15A560	DE15A500
Prime	437	405	365	330
Standby	485	450	415	365
Continuous	360	308	277	251

Ratings (kW)	1800rpm / 60Hz		
	DE15B700	DE15B620	DE15B560
Prime	465	405	375
Standby	515	455	415
Continuous	353	308	285

GENERAL ENGINE DATA

Engine Model	DE15A660	DE15A610	DE15A560	DE15A500	DE15B700	DE15B620	DE15B560
Engine Type	4-Cycle, V-type, 8-Cylinder, Turbo charger & intercooler (air to air)						
Speed	1500rpm			1800rpm			
Bore x stroke	128 * 142 mm						
Displacement	14.618 L						
Compression ratio	14.6 : 1						
Rotation {Looking at flywheel}	Counter clockwise {CCW}						
Firing order	1-5-7-2-6-3-4-8						
Injection timing	18°±1° BTDC @ 1500rpm			20°±1° BTDC @1800 rpm			
Dry weight {W/O cooling system}	1050 kg						
Dimension {L x W x H}	1481*1389*1288 mm						
Flywheel housing	SAE 1						
Flywheel	14{PCD:438.15mm/17.25inch}						
Number of teeth on flywheel	150						
Piston speed	200 m/s			240 m/s			
ENGINE MOUNTING							
Max.Bending Moment at Rear Face to Block	1325 N.m						

DE15 Series Engine

INTAKE & EXHAUST SYSTEM

Engine Model	DE15A660	DE15A610	DE15A560	DE15A500	DE15B700	DE15B620	DE15B560
Max.Intake Restriction (kPa)	5						
Max.Exhaust Back Pressure (kPa)	10						
Combustion Air Consumption (m ³ /h)	3077	2750	2495	2180	3088	2755	2410
Max.Exhaust Temp.(After Turbo°C)	530	515	495	445	525	505	470
Exhaust Gas Flow (m ³ /h)	7457	6515	5712	4720	7620	6551	5456
Cooling fan air flow (m ³ /min)	713m ³ /min @1500rpm				810m ³ /min @1800rpm		

AIR INDUCTION SYSTEM

Engine Model	DE15A660	DE15A610	DE15A560	DE15A500	DE15B700	DE15B620	DE15B560
Maximum Intake Air Restriction							
- With Clean Filter Element (m ³ /h)	2927	2702	2406	2127	3139	2705	2443
- With Dirty Filter Element (m ³ /h)	8430	7782	6929	6126	9040	7790	7036
Max.static pressure after radiator (Pa)	1126 Pa @1500rpm				955 Pa @1800rpm		

COOLING SYSTEM

Water circulation by centrifugal pump on engine

Cooling method	Fresh water forced circulation
Coolant capacity	Engine only : Approx.23 lit, With Radiator (*Air On 43°C : Approx 114 lit)
Coolant flow rate	660 liters / min @1800 rpm, 550 liters / min @1500 rpm
Pressure Cap	49 kPa
Coolant Capacity for Engine	Engine 20L + Radiator 75L
Max.Permissible Temperature	90 °C
Max.Coolant warning Temperature	95 °C
Max.Coolant Shutdown Temperature	105 °C
Thermostat Open Temperature	71 °C
Max.external coolant system restriction	Not available

Two radiator options are provided, based on allowable maximum Air temperature On radiator inlet (Air On 40 °C) Air On 50 °C

- ATB (Ambient Temperature before Boiling) of generator set varies depending on the engine room ventilation design, even if the same radiator applied. Adequate selection of radiator options by means of the cooling test is highly recommended, and generator set makers are responsible for the selection.

LUBRICATION SYSTEM

Force-feed lubrication by gear pump, lubricating oil cooling water circuit of engine

Lub.Method	Fully forced pressure feed type
Oil filter	Full flow, cartridge type
Lube oil specification	CF-4
Lub oil pressure	Idle Speed : Min 160 kPa Governed Speed: Min 200 kPa
Maximum oil temperature	110 °C
Max.Permissible Oil Temperature	90 °C
Oil Consumption (as % of fuel consumption)	≤0.5
Oil capacity	27 L

DE15 Series Engine

FUEL SYSTEM

High pressure common rail

Engine Model	DE15A660	DE15A610	DE15A560	DE15A500	DE15B700	DE15B620	DE15B560
Governor	ECU						
Speed drop	G2 Class (ISO 8528)						
Feed pump	Mechanical type in injpump						
Injection nozzle	Multi hole type						
Opening pressure	28 MPa						
Fuel filter	Full flow, Cartridge type with water drain valve						
Maximum fuel inlet restriction	30 kPa						
Maximum fuel return restriction	60 kPa						
Fuel feed pump Capacity	315 L/h						
Fuel	Diesel fuel						
Fuel consumption							
Standby power- 100% load (L/h)	122.8	113.9	101.4	88.7	134.1	113.0	103.7
Prime Power - 100% load (L/h)	109.4	100.5	88.6	79.8	119.4	99.8	91.7
- 75% load (L/h)	81.0	73.5	64.8	59.0	87.0	73.4	68.2
- 50% load (L/h)	55.1	50.6	45.3	40.7	59.8	49.5	45.9
- 25% load (L/h)	29.7	27.3	24.9	22.7	34.5	28.8	26.7
Continous power - 100% load (L/h)	82	75	66	60	88	74	69
Fuel Consumption Ratio (g/kW.h)	196-205 g/kW.h						

ELECTRICAL SYSTEM

Charging Alternator Voltage	28V						
Charging Alternator Capacity	45A						
Voltage regulator	Built-in type IC regulator						
Starting motor	7kW						
Battery Voltage	24V						
Battery Capacity	2 * 200 Ah						
Starting aid (Option)	Block heater (Min. Temperature for Unaided Cold Start -10°C)						

VALVE SYSTEM

Type	Overhead valve type						
Number of valve	Intake 1, exhaust 1 per cylinder						
Valve lashes at cold	Intake 0.3 mm, Exhaust 0.4 mm						
Valve timing							
	Opening			Close			
- Intake valve	24 deg.BTDC			36 deg.ABDC			
- Exhaust valve	63 deg.BBDC			27 deg.ATDC			

DE15 Series Engine

Engine Data with Dry Exhaust Manifold (Standby Power)

Engine Model	DE15A660	DE15A610	DE15A560	DE15A500	DE15B700	DE15B620	DE15B560
Cooling Water Circulation	590 L/min (1500 rpm)				660L/min (1800 rpm)		
Heat Rejection to Exhaust (kW)	396	353	319	276	411	358	318
Heat Rejection to Coolant (kW)	173	154	139	120	179	156	138
Heat Rejection to Intercooler (kW)	115	102	93	80	119	104	92
Radiated Heat to Ambient (kW)	63	56	51	44	66	57	51

Engine Data with Dry Exhaust Manifold (Prime Power)

Engine Model	DE15A660	DE15A610	DE15A560	DE15A500	DE15B700	DE15B620	DE15B560
Cooling Water Circulation	590 L/min (1500 rpm)				660L/min (1800 rpm)		
Heat Rejection to Exhaust (kW)	356	318	287	248	370	322	286
Heat Rejection to Coolant (kW)	156	139	125	108	161	140	124
Heat Rejection to Intercooler (kW)	104	92	84	72	107	94	83
Radiated Heat to Ambient (kW)	57	50	46	40	59	51	46

DE15 (V8) SERIES T3 DIESEL ENGINE DRAWING

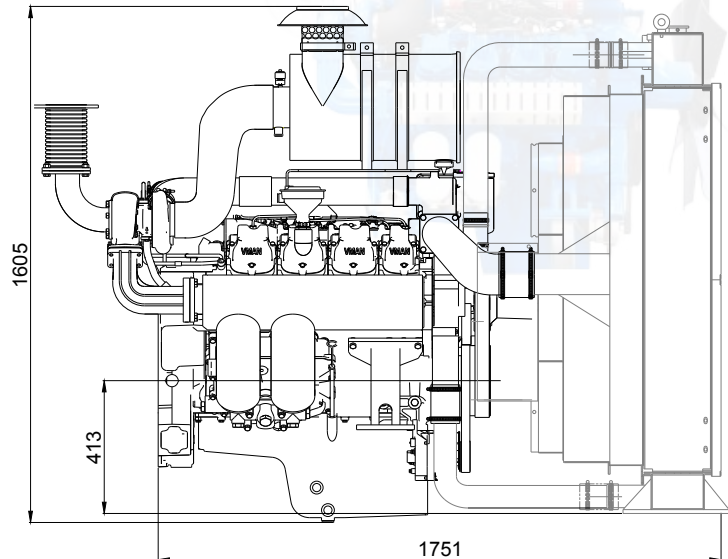
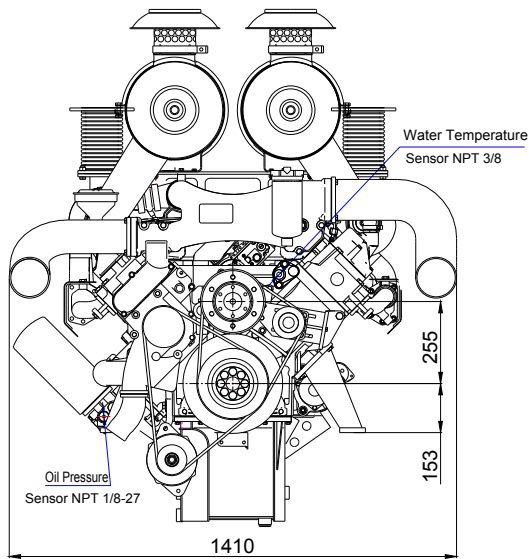

DE22 Series Engine



Ratings (kW)	1500rpm / 50Hz					
	DE22A990	DE22A950	DE22A840	DE22A780	DE22A750	DE22A690
Prime	657	630	555	535	515	455
Standby	730	700	620	576	555	505
Continuous	493	479	422	407	391	346

Ratings (kW)	1800rpm / 60Hz				
	DE22B1080	DE22B1000	DE22B930	DE22B850	DE22B770
Prime	718	671	620	555	510
Standby	790	739	682	627	566
Continuous	546	510	471	422	388

GENERAL ENGINE DATA

Engine Model	DE22A990	DE22A950	DE22A840	DE22A780	DE22A750	DE22A690	DE22B1080	DE22B1000	DE22B930	DE22B850	DE22B770
Engine Type	4-Cycle, V-type, 12-Cylinder, Turbo charger & intercooler (air to air)										
Speed	1500 rpm						1800 rpm				
Bore x stroke	128 * 142 mm										
Displacement	21.927 L										
Compression ratio	14.6 : 1	15.5 : 1				14.6 : 1		15.5 : 1			
Rotation (Looking at flywheel)	Counter clockwise viewed from Flywheel										
Firing order	1-12-5-8-3-10-6-7-2-11-4-9										
Injection timing	18°±1° BTDC @1500rpm						20°±1° BTDC @1800rpm				
Dry weight (W/O cooling system)	1575 kg										
Dimension (L x W x H)	1717*1389*1288 mm										
Flywheel housing	SAE 1 or SAE 0										
Flywheel	14{PCD:438.15mm/17.25inch} or 18{PCD:543mm/31.38inch}										
Number of teeth on flywheel	150										
Piston speed	200 m/s						240m/s				
ENGINE MOUNTING											
Max.Bending Moment at Rear Face to Block	1325 N.m										

DE22 Series Engine

INTAKE & EXHAUST SYSTEM

Engine Model	DE22A990	DE22A950	DE22A840	DE22A780	DE22A750	DE22A690	DE22B1080	DE22B1000	DE22B930	DE22B850	DE22B770
Max.Intake Restriction	5 kPa										
Max.Exhaust Back Pressure	10 kPa										
Combustion Air Consumption(m ³ /h)	4480	4204	3477	3393	3309	2958	4838	4504	4096	3728	3396
Max.Exhaust Temp.(After Turbo°C)	550	545	540	528	513	502	545	540	525	510	480
Exhaust Gas Flow (m ³ /h)	11361	10662	8712	8364	8015	7064	12197	11284	10072	8996	7882
Cooling fan air flow (m ³ /min)	863	863	750	750	720	720	1100	1100	950	950	950

AIR INDUCTION SYSTEM

Engine Model	DE22A990	DE22A950	DE22A840	DE22A780	DE22A750	DE22A690	DE22B1080	DE22B1000	DE22B930	DE22B850	DE22B770
Maximum Intake Air Restriction											
- With Clean Filter Element (m ³ /h)	4406	4162	3539	3322	3217	2928	4822	4460	4075	3709	3315
- With Dirty Filter Element (m ³ /h)	12689	11987	10192	9567	9265	8433	13887	12845	11736	10682	9547
Max.static pressure after radiator	662 Pa @1500rpm						732.5 Pa @1800rpm				

COOLING SYSTEM

Water circulation by centrifugal pump on engine

Cooling method	Fresh water forced circulation
Coolant capacity	Engine only : Approx.23 lit, With Radiator (*Air On 43°C : Approx 114 lit)
Coolant flow rate	660 liters / min @1800 rpm, 590 liters / min @1500 rpm
Pressure Cap	49 kPa
Coolant Capacity for Engine	Engine 23L + Radiator 96L
Max.Permissible Temperature	90 °C
Max.Coolant warning Temperature	95 °C
Max.Coolant Shutdown Temperature	105 °C
Thermostat Open Temperature	71 °C
Max.external coolant system restriction	Not available

Two radiator options are provided, based on allowable maximum Air temperature On radiator inlet (Air On 40 °C) Air On 50 °C

- ATB (Ambient Temperature before Boiling) of generator set varies depending on the engine room ventilation design, even if the same radiator applied. Adequate selection of radiator options by means of the cooling test is highly recommended, and generator set makers are responsible for the selection.

LUBRICATION SYSTEM

Force-feed lubrication by gear pump, lubricating oil cooling water circuit of engine

Lub.Method	Fully forced pressure feed type
Oil filter	Full flow, cartridge type
Lube oil specification	CF-4
Lub oil pressure	Idle Speed : Min 160 kPa Governed Speed: Min 200 kPa
Maximum oil temperature	110 °C
Max.Permissible Oil Temperature	90 °C
Oil Consumption (as % of fuel consumption)	≤0.5
Oil capacity	57 L

DE22 Series Engine

FUEL SYSTEM

High pressure common rail

Engine Model	DE22A990	DE22A950	DE22A840	DE22A780	DE22A750	DE22A690	DE22B1080	DE22B1000	DE22B930	DE22B850	DE22B770
Governor	ECU										
Speed drop	G2 Class (ISO 8528)										
Feed pump	Mechanical type in injpump										
Injection nozzle	Multi hole type										
Opening pressure	28 MPa										
Fuel filter	Full flow, Cartridge type with water drain valve										
Maximum fuel inlet restriction	30 kPa										
Maximum fuel return restriction	60 kPa										
Fuel feed pump Capacity	630 L/h										
Fuel	Diesel fuel										
Fuel consumption											
Standby power- 100% load (L/h)	182.9	176.0	154.9	140.0	134.9	121.7	206.5	192.3	174.9	157.3	141.2
Prime Power - 100% load (L/h)	165.2	156.8	132.4	128.0	123.2	109.3	185.5	173.4	157.2	137.8	126.0
- 75% load (L/h)	122.1	115.0	97.3	95.2	91.7	81.6	136.3	127.5	115.1	102.2	93.6
- 50% load (L/h)	82.4	78.2	66.4	65.1	62.7	55.7	97.3	90.5	82.5	72.4	66.1
- 25% load (L/h)	46.5	44.0	39.0	39.8	38.3	34.2	58.2	54.2	47.6	42.0	38.3
Continous power - 100% load (L/h)	123	116	98	96	93	82	137	128	116	103	95
Fuel Consumption Ratio (g/kW.h)	192-204 g/kW.h										

ELECTRICAL SYSTEM

Charging Alternator Voltage	28V
Charging Alternator Capacity	45A
Voltage regulator	Built-in type IC regulator
Starting motor	9kW
Battery Voltage	24V
Battery Capacity	2 * 200 Ah (recommended)
Starting aid (Option)	Block heater (Min. Temperature for Unaided Cold Start -10°C)

VALVE SYSTEM

Type	Overhead valve type	
Number of valve	Intake 1, exhaust 1 per cylinder	
Valve lashes at cold	Intake 0.3 mm, Exhaust 0.4 mm	
Valve timing		
	Opening	Close
- Intake valve	24 deg.BTDC	36 deg.ABDC
- Exhaust valve	63 deg.BBDC	27 deg.ATDC

DE22 Series Engine

Engine Data with Dry Exhaust Manifold (Standby Power)

Engine Model	DE22A990	DE22A950	DE22A840	DE22A780	DE22A750	DE22A690	DE22B1080	DE22B1000	DE22B930	DE22B850	DE22B770
Cooling Water Circulation	590 L/min @1500rpm						660 L/min @1800rpm				
Heat Rejection to Exhaust (kW)	578	551	475	453	431	378	646	604	548	493	452
Heat Rejection to Coolant (kW)	252	240	207	198	188	165	282	263	239	215	197
Heat Rejection to Intercooler (kW)	168	160	138	132	125	110	188	175	159	143	131
Radiated Heat to Ambient (kW)	92	88	76	73	69	60	103	97	88	79	72

Engine Data with Dry Exhaust Manifold (Prime Power)

Engine Model	DE22A990	DE22A950	DE22A840	DE22A780	DE22A750	DE22A690	DE22B1080	DE22B1000	DE22B930	DE22B850	DE22B770
Cooling Water Circulation	590 L/min @ 1500 rpm						660 L/min @ 1800 rpm				
Heat Rejection to Exhaust (kW)	520	496	428	408	388	340	581	544	493	444	407
Heat Rejection to Coolant (kW)	227	216	186	178	169	149	254	237	215	194	177
Heat Rejection to Intercooler (kW)	151	144	124	119	113	99	169	158	143	129	118
Radiated Heat to Ambient (kW)	83	79	68	66	62	54	93	87	79	71	65

DE22 (V12) SERIES T3 DIESEL ENGINE DRAWING

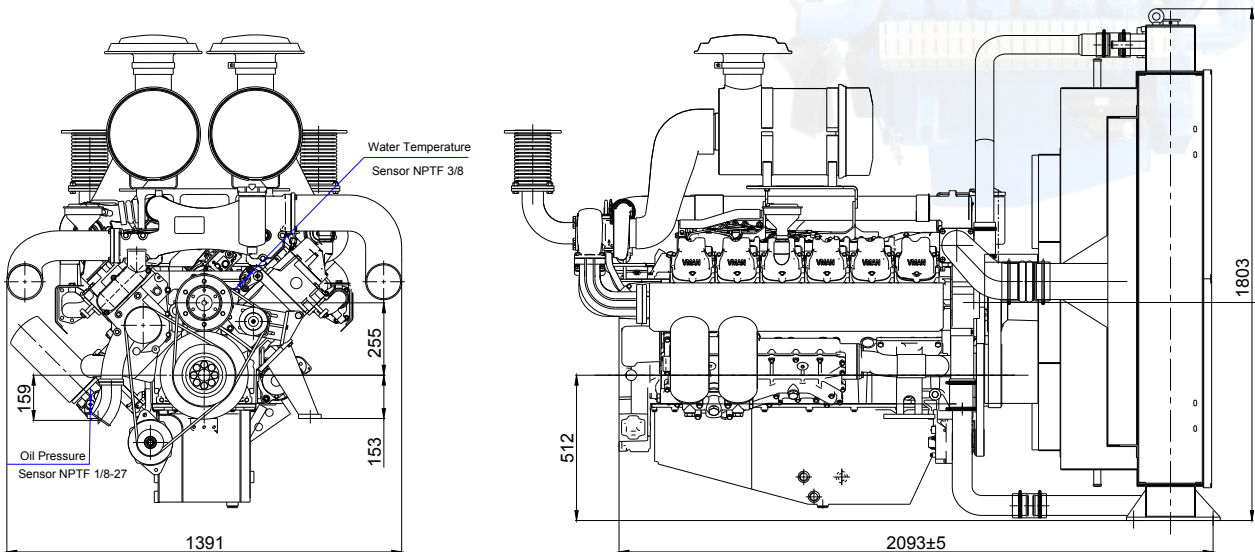

DE30 Series Engine



Ratings (kW)	1500rpm / 50Hz			
	DE30A1400	DE30A1320	DE30A1220	DE30A1080
Prime	920	880	818	718
Standby	1020	970	900	790
Continuous	705	669	622	546

Ratings (kW)	1800rpm / 60Hz			
	DE30B1400	DE30B1310	DE30B1240	DE30B1160
Prime	920	880	825	750
Standby	1020	965	910	855
Continuous	705	669	627	570

GENERAL ENGINE DATA

Engine Model	DE30A1400	DE30A1320	DE30A1220	DE30A1080	DE30B1400	DE30B1310	DE30B1240	DE30B1160
Engine Type	4-Cycle, V-type, 16-Cylinder, Turbo charger & intercooler (air to air)							
Speed	1500 rpm				1800 rpm			
Bore x stroke	128 * 142 mm							
Displacement	29.235 L							
Compression ratio	14.6 : 1	15.5 : 1			14.6:1	15.5 : 1		
Rotation (Looking at flywheel)	Counter clockwise viewed from Flywheel							
Firing order	1-15-6-12-8-5-16-7-11-4-9-2-14-10-3-13							
Injection timing	18°±1° BTDC @ 1500 rpm				20°±1° BTDC @ 1800 rpm			
Dry weight (W/O cooling system)	2100 kg							
Dimension (L x W x H)	2340*1392*1360 mm							
Flywheel housing	SAE 0							
Flywheel	18(PCD:543mm/31.38inch)							
Number of teeth on flywheel	160							
Piston speed	200m/s				240 m/s			
ENGINE MOUNTING								
Max.Bending Moment at Rear Face to Block	1325 N.m							

DE30 Series Engine

AIR INDUCTION SYSTEM

Engine Model	DE30A1400	DE30A1320	DE30A1220	DE30A1080	DE30B1400	DE30B1310	DE30B1240	DE30B1160
Maximum Intake Air Restriction								
- With Clean Filter Element (m ³ /h)	6277	5652	5218	4603	6520	5824	5276	4957
- With Dirty Filter Element (m ³ /h)	18078	16278	15028	13257	18778	16773	15195	14276
Max.static pressure after radiator (Pa)	1500 Pa @1500rpm				3000 Pa @1800rpm			

COOLING SYSTEM

Water circulation by centrifugal pump on engine

Cooling method	Fresh water forced circulation
Coolant capacity	Engine only : Approx.23 lit, With Radiator (*Air On 43°C : Approx 114 lit)
Coolant flow rate	660 liters / min @1800 rpm, 550 liters / min @1500 rpm
Pressure Cap	49 kPa
Coolant Capacity for Engine	Engine 26 L + Radiator 125L
Max.Permissible Temperature	90 °C
Max.Coolant warning Temperature	95 °C
Max.Coolant Shutdown Temperature	105 °C
Thermostat Open Temperature	71 °C
Max.external coolant system restriction	Not available

Two radiator options are provided, based on allowable maximum Air temperature On radiator inlet (Air On 40 °C Air On 50 °C

- ATB (Ambient Temperature before Boiling) of generator set varies depending on the engine room ventilation design, even if the same radiator applied. Adequate selection of radiator options by means of the cooling test is highly recommended, and generator set makers are responsible for the selection.

LUBRICATION SYSTEM

Force-feed lubrication by gear pump, lubricating oil cooling water circuit of engine

Lub.Method	Fully forced pressure feed type
Oil filter	Full flow, cartridge type
Lube oil specification	CF-4
Lube oil pressure	Idle Speed : Min 160 kPa Governed Speed: Min 200 kPa
Maximum oil temperature	110 °C
Max.Permissible Oil Temperature	90 °C
Oil Consumption (as % of fuel consumption)	≤0.5
Oil capacity	78 L

ELECTRICAL SYSTEM

Charging Alternator Voltage	28V
Charging Alternator Capacity	45A
Voltage regulator	Built-in type IC regulator
Starting motor	24V * 11kW
Battery Voltage	24V
Battery Capacity	2 * 250 Ah (recommended)
Starting aid (Option)	Block heater (Min. Temperature for Unaided Cold Start -10°C)

DE30 Series Engine

FUEL SYSTEM

High pressure common rail

Engine Model	DE30A1400	DE30A1320	DE30A1220	DE30A1080	DE30B1400	DE30B1310	DE30B1240	DE30B1160
Governor	ECU							
Speed drop	G2 Class (ISO 8528)							
Feed pump	Mechanical type in injpump							
Injection nozzle	Multi hole type							
Opening pressure	28 MPa							
Fuel filter	Full flow, Cartridge type with water drain valve							
Maximum fuel inlet restriction	30 kPa							
Maximum fuel return restriction	60 kPa							
Fuel feed pump Capacity	739 L/h							
Fuel	Diesel fuel							
Fuel consumption								
Standby power- 100% load (L/h)	267.2	248.9	228.1	198.2	272.0	249.5	218.4	206.0
Prime Power - 100% load (L/h)	240.1	223.3	205.1	177.5	246.6	222.9	196.8	179.0
- 75% load (L/h)	177.8	165.5	152.3	129.0	181.9	163.7	147.1	137.0
- 50% load (L/h)	122.9	115.7	106.8	92.6	130.7	115.0	104.1	95.8
- 25% load (L/h)	73.2	68.9	62.3	53.9	73.5	66.3	60.1	55.4
Continous power - 100% load (L/h)	179	167	154	130	184	165	150	139
Fuel Consumption Ratio (g/kW.h)	195-215 g/kW.h							

VALVE SYSTEM

Type	Overhead valve type							
Number of valve	Intake 1, exhaust 1 per cylinder							
Valve lashes at cold	Intake 0.3 mm, Exhaust 0.4 mm							
Valve timing								
	Opening				Close			
- Intake valve	24 deg.BTDC				36 deg.ABDC			
- Exhaust valve	63 deg.BBDC				27 deg.ATDC			

Engine Data with Dry Exhaust Manifold (Standby Power)

Engine Model	DE30A1400	DE30A1320	DE30A1220	DE30A1080	DE30B1400	DE30B1310	DE30B1240	DE30B1160
Cooling Water Circulation	866 L/min @ 1500 rpm				1040 L/min @ 1800 rpm			
Heat Rejection to Exhaust (kW)	835	778	713	619	850	780	682	644
Heat Rejection to Coolant (kW)	364	339	311	270	370	340	297	281
Heat Rejection to Intercooler (kW)	242	226	207	180	247	226	198	187
Radiated Heat to Ambient (kW)	133	124	114	99	136	125	109	103

DE30 Series Engine

Engine Data with Dry Exhaust Manifold (Prime Power)

Engine Model	DE30A1400	DE30A1320	DE30A1220	DE30A1080	DE30B1390	DE30B1310	DE30B1240	DE30B1160
Cooling Water Circulation	866 L/min @ 1500 rpm				1040 L/min @ 1800 rpm			
Heat Rejection to Exhaust (kW)	752	700	642	557	765	702	614	580
Heat Rejection to Coolant (kW)	328	305	280	243	333	306	267	253
Heat Rejection to Intercooler (kW)	218	203	186	162	222	203	178	168
Radiated Heat to Ambient (kW)	120	112	103	89	122	113	98	93

DE30 (V16) SERIES T3 DIESEL ENGINE DRAWING

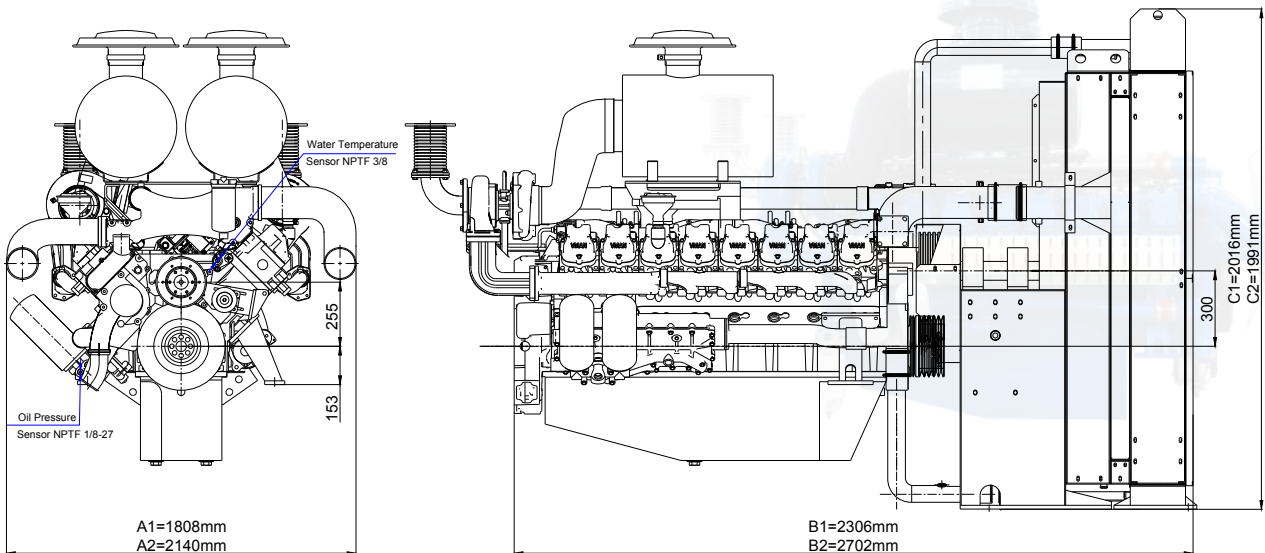

The size of A1 B1 C1 for D30A3 & D30B4
 The size of A2 B2 C2 for D30AP D30A D30A1 D30A2 & D30BP D30B1 D30B2 D30B3

DE58 Series Engine



Model	Gross Engine Output		Typical Generator Output			
	PRP	ESP	PRP		ESP	
	kWm		kWe	kVA	kWe	kVA
DE58A5	1380	1518	1200	1500	1320	1650
DE58A4	1520	1672	1350	1688	1485	1856
DE58A3	1685	1854	1500	1875	1650	2063
DE58A2	1820	2002	1650	2063	1816	2270
DE58A1	2020	2222	1800	2250	2000	2500

Note: PRP - Prime Rated Power; ESP - Emergency Standby Power

GENERAL ENGINE DATA

Engine Model	DE58A1	DE58A2	DE58A3	DE58A4	DE58A5
Engine Type	V-type, 4-Stroke, 4-Valve, 12-Cylinder, Water-cooling, Turbocharged Intercooled				
Speed	1500 rpm				
Bore x stroke	170 × 210 mm				
Displacement	57.2 L				
Compression ratio	18 : 1				
Rotation {Looking at flywheel}	Counter clockwise {CCW}				
Firing order	A1-B5-A5-B3-A3-B6-A6-B2-A2-B4-A4-B1				
Dry weight {W/O cooling system}	7610 kg				
Dimension {L x W x H}	2762 × 1582 × 2193 mm				
Flywheel housing	SAE 00#				
Flywheel	SAE 21#				
Combustion method	Direct				
Cylinder type	Wet Cylinder Liner				
Injector Advance Angle	Electronic				

DE58 Series Engine

DIESEL ENGINE DATA

Engine Model	DE58A1	DE58A2	DE58A3	DE58A4	DE58A5
Intake flow	149.6 m ³ /min	138.4 m ³ /min	124.6 m ³ /min	113.2 m ³ /min	100.9 m ³ /min
Exhaust flow	328.6 m ³ /min	303.9 m ³ /min	273.6 m ³ /min	239.4 m ³ /min	221.4 m ³ /min
Exhaust temperature	700 °C (before vortex)				
Maximum permissible resistance	2.5 kPa (new cartridge)				
	Intake system	6.2 kPa (needs replacing)			
	Exhaust system	10 kPa (max)			

COOLING SYSTEM

Engine Model	DE58A1	DE58A2	DE58A3	DE58A4	DE58A5
Coolant capacity (Engine + water air coole	194.4 L				
Pressure Cap	90 kPa				
High temperature water pump	Centrifugal, gear driven				
	Pump flow rate	> 1140 L/min			
	Thermostat	Wax 77 °C - 90 °C			
	Maximum resistance of the external cooling system	40 kPa			
Low temperature water pump	Centrifugal, gear driven				
	Pump flow rate	> 1136 L/min			
	Thermostat	Wax 40 °C - 52 °C			
	Maximum resistance of the external cooling system	60 kPa			
Maximum Engine Coolant Temperature	Prime		98 °C		
	Standby		102 °C		

Two radiator options are provided, based on allowable maximum Air temperature On radiator inlet (Air On 40 °C) Air On 50 °C

- ATB (Ambient Temperature before Boiling) of generator set varies depending on the engine room ventilation design, even if the same radiator applied. Adequate selection of radiator options by means of the cooling test is highly recommended, and generator set makers are responsible for the selection.

ENGINE EMISSION DATA

Engine Model	DE58A1	DE58A2	DE58A3	DE58A4	DE58A5
CO [g/(kw.h)]	0.82				
HC+NOx [g/(kw.h)]	5.42				
PM [g/(kw.h)]	0.121				

DE58 Series Engine

FUEL SYSTEM

Engine Model	DE58A1	DE58A2	DE58A3	DE58A4	DE58A5
Feed pump	Common rail				
Governor	Electric type				
Oil pump	Electrical				
Injection nozzle	Multi hole type				
Opening pressure	Electrical				
Fuel filter	Spin-on Full-flow				
Fuel	Light diesel				
Maximum fuel inlet restriction	130kPa (abs)				
Minimum fuel return restriction	50kPa (abs)				
Fuel feed pump Capacity	1289 L/h				
Fuel	Diesel fuel				
Fuel consumption					
Standby power- 100% load (L/h)	515.9	469.5	443.4	407.9	375.7
Prime Power - 100% load (L/h)	473.7	431.2	407.2	374.6	345.0
- 75% load (L/h)	358.9	326.6	308.5	283.7	261.3
- 50% load (L/h)	241.6	219.9	207.7	191.0	176.0
- 25% load (L/h)	122.0	111.0	104.9	96.5	88.8
Continuous power - 100% load (L/h)	364.8	332.0	313.6	288.4	265.7
Fuel Consumption Ratio (g/kW.h)	197	199	203	207	210

LUBRICATION SYSTEM

Engine Model	DE58A1	DE58A2	DE58A3	DE58A4	DE58A5
Lub.Method	Fully forced pressure and splash				
Oil pump	Crankshaft driven gear method				
Filter	5 × Spin-on full flow type 1 × Spin-on bypass type				
Oil capacity	Upper limit: 313 L Lower limit: 222 L				
Maximum oil temperature	110 °C				

ELECTRICAL SYSTEM

Engine Model	DE58A1	DE58A2	DE58A3	DE58A4	DE58A5
Generator	27 V x 55 A (two-wire)				
Voltage regulator	Inline, Integrated circuit regulator				
Starting motor	24 V x 8.5 kW x 2 (two-wire)				
Battery voltage	24 V				
Battery capacity	6x200 AH				

DE58 Series Engine

VALVE SYSTEM

Type	Overhead valve type		
Number of valve	Intake 2, exhaust 2 per cylinder		
Valve lashes at cold	Intake 0.45 mm, Exhaust 0.80 mm		
Valve timing			
	Opening	Close	
-Intake valve	33°BTDC	48°ABDC	
-Exhaust valve	68°BBDC	34°ATDC	

DE58 (V12) SERIES DIESEL ENGINE DRAWING

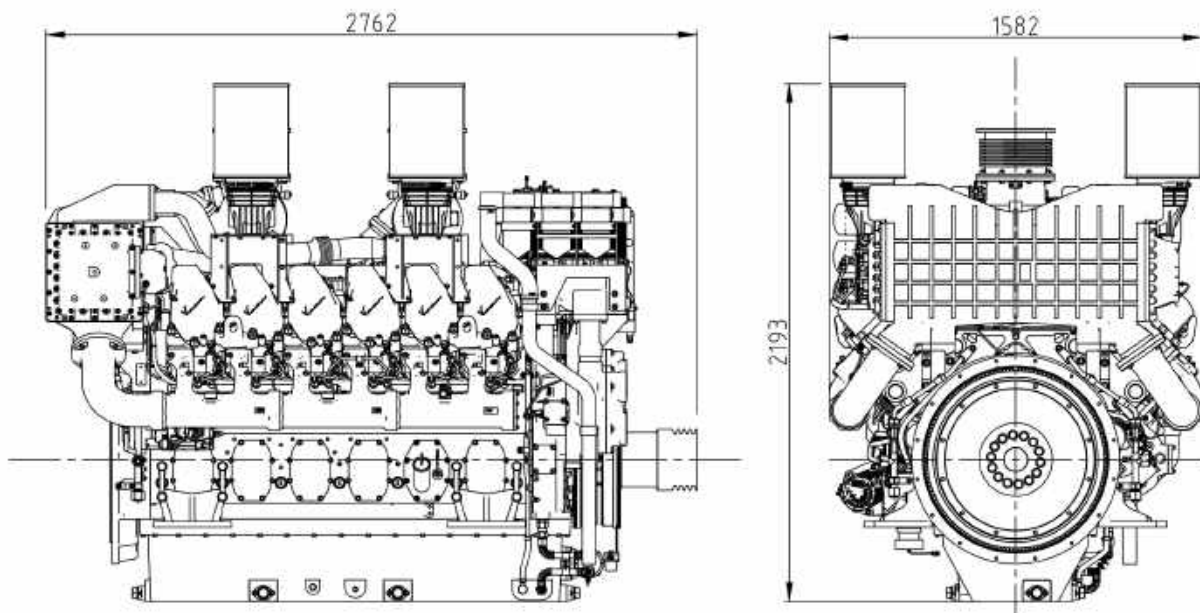

Marine Engine



Model	Type	Speed (rpm)	Power (HP)	Power (kW)	Disp. (L)	Size (mm)	Applications
CE12C1	L6	1500	426	318	11.8	1780 x 984 x 1388	Marine Auxiliary Engines
CE12C2		1800	430	321			
CE13C1	L6	1500	547	408	12.8	1360 x 898 x 1138	
CE13C2		1800	548	409			
D15C1	V8	1500	412	307	14.6	1650 x 1230 x 1324	
D15C2		1800	480	358			
D22C1	V12	1500	605	451	21.9	1941 x 1230 x 1325	
D22C2		1800	717	535			
D30C1	V16	1500	805	600	29.2	2340 x 1230 x 1410	
D30C2		1800	959	715			
CE12D	L6	1800	430	321	11.8	1780 x 984 x 1388	Marine Propulsion Engines
CE13D	L6	1800	548	409	12.8	1360 x 898 x 1138	
D15D	V8	1800	480	358	14.6	1650 x 1230 x 1324	
D22D	V12	1800	717	535	21.9	1941 x 1230 x 1325	
D30D	V16	1800	959	715	29.2	2340 x 1230 x 1410	

Marine Propulsion Engine of D Series



Model	Type	Speed (rpm)	Power (HP)	Power (kW)	Disp. (L)
D15D	V8	1800	480	358	14.6
D22D	V12	1800	717	535	21.9
D30D	V16	1800	959	715	29.2

Note:

1. No reduction in rating for intake air temperature is up to 45°C (318K) and sea water temperature is up to 32 °C (305K) , relative humidity is up to 60 % all data are based on operation to ISO 3046;
2. Operation hours are unlimited per year, at average load is up to 90 % , at full load is up to 80 %;
3. Typical gearbox ratio: 2.5 ~ 6 (Fishing trawler, Tug boat, Pushing vessel, Cargo boat, Freighter, Ferry).

D SERIES PROPULSION ENGINE SPECIFICATION

Engine Model	D15D	D22D	D30D
Engine Type	4 cycle,direct- injection, water cooled with wet turbo charger & inter-cooler		
	V8 type	V12 type	V16 type
Rating output (kW/rpm)	358/1800	535/1800	715/1800
Rating output (HP/rpm)	480/1800	717/1800	959/1800
Displacement (L)	14.618	21.927	29.235
Cylinder number - bore(Φ) x stroke (mm)	8- Φ128 x 142	12- Φ128 x 142	16- Φ128 x 142
Valve clearance at cold - In / Ex (mm)	0.3 / 0.4	0.3 / 0.4	0.3 / 0.4
Low idling (rpm)	725 ± 25		
No load max. (rpm)	2070		
Mean effective pressure (kg/cm ²)	16.4	16.3	16.3
Mean piston speed (m/sec)	8.52		
Compression ratio	15.5 : 1		
Firing order	1-5-7-2-6-3-4-8	1-12-5-8-3-10-6-7-2-11-4-9	1-15-6-12-8-5-16-7-11-4-9-2-14-10-3-13
Governor type of injection pump	Mechanical pump with GAC6500 electronic variable speed controller		
Fuel consumption (g/kW.h)	200	202	204
Fuel consumption (Lit./h)	84	127	172
Injection timing (B.T.D.C)	20 °± 1°		

Marine Propulsion Engine of D Series

D SERIES PROPULSION ENGINE SPECIFICATION

Engine Model	D15D	D22D	D30D
Starting system	Electric Starting by starter motor		
Starter motor capacity (V - kW)	24-7	24-9	24-11
Alternator capacity (V - A)	24-45		
Battery (V - Ah)	24-200	24-400	24-500
Cooling system	Indirect sea water cooling with heat exchanger		
Cooling water capacity - Max. / Min (lit.)	89/78	98/87	107/96
Fresh water pump type	Centrifugal type, driven by belt		
Sea water pump type	Bronze impeller type driven by belt		
Lubricating oil - pan capacity (lit.)	Max:27, Min:19	Max:57, Min:41	Max:78, Min:60
Lubricating oil - pressure (kg/cm ²)	Full : 3.5; Idle : 1.2		
Direction of revolution - crankshaft	Counter clockwise viewed from stern side		
Engine Size (L x W x H) (mm)	1656x1230x1324	1941x1230x1325	2340x1230x1410
Engine dry weight (kg)	1350	1750	2100

D SERIES PROPULSION ENGINE DRAWING

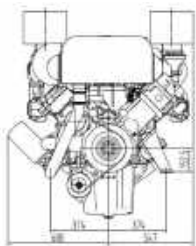

D15/22/30D

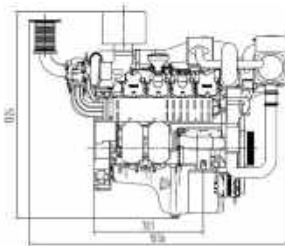

D15D

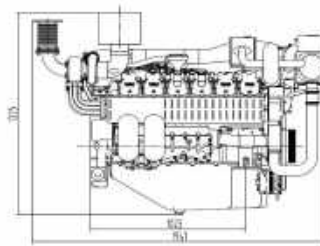

D22D

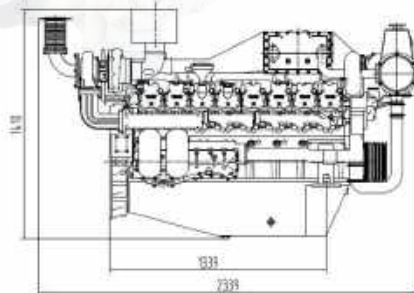

D30D

Marine Propulsion Engine of C Series

Model	Type	Speed (rpm)	Power (HP)	Power (kW)	Disp. (L)
CE12D	L6	1800	430	321	11.8
CE13D	L6	1800	548	409	12.8



Note:

1. No reduction in rating for intake air temperature is up to 45°C (318K) and sea water temperature is up to 32 °C (305K) , relative humidity is up to 60 % all data are based on operation to ISO 3046;
2. Operation hours are unlimited per year, at average load is up to 90 %, at full load is up to 80 %;
3. Typical gearbox ratio: 2.5 ~ 6 (Fishing trawler, Tug boat, Pushing vessel, Cargo boat, Freighter, Ferry).

CE SERIES PROPULSION ENGINE SPECIFICATION

Engine Model	CE12D	CE13D
Engine Type	4 cycle, direct- injection, water cooled with wet turbo charger & inter-cooler	
	L6 type	L6 type
Rating output (kW/rpm)	321/1800	409/1800
Rating output (HP/rpm)	430/1800	548/1800
Displacement (L)	11.8	12.8
Cylinder number - bore(Φ) x stroke (mm)	6- Φ128 x 153	16- Φ130 x 161
Valve clearance at cold - In / Ex (mm)	0.4 / 0.65	0.4 / 0.65
Low idling (rpm)	650 ± 25	
No load max. (rpm)	1858	
Mean effective pressure (kg/cm ²)	20.2	21.7
Mean piston speed (m/sec)	9.2	9.66
Compression ratio	17 : 1	
Firing order	1-5-3-6-2-4	
Governor type of injection pump	Common rail with ECU	
Fuel consumption (g/kW.h)	190	190
Fuel consumption (Lit./h)	72	176
Injection timing (B.T.D.C)	7.5 °± 3°	10 °± 1.5°

Marine Propulsion Engine of C Series

CE SERIES PROPULSION ENGINE SPECIFICATION

Engine Model	CE12D	CE13D
Starting system	Electric Starting by starter motor	
Starter motor capacity (V - kW)	24-7.5	
Alternator capacity (V - A)	24-70	
Battery (V - Ah)	24-150	
Cooling system	Indirect sea water cooling with heat exchanger	
Cooling water capacity - Max. / Min (lit.)	45/40	
Fresh water pump type	Centrifugal type, driven by belt	
Sea water pump type	Bronze impeller type driven by belt	
Lubricating oil - pan capacity (lit.)	Max:37, Min:33	Max:41, Min:38
Lubricating oil - pressure (kg/cm ²)	Full : 5.6; Idle : 1.57	
Direction of revolution - crankshaft	Counter clockwise viewed from stern side	
Engine Size (L x W x H) (mm)	1780 x984 x1549	1780 x1014 x1510
Engine dry weight (kg)	1265	1170

D SERIES PROPULSION ENGINE DRAWING

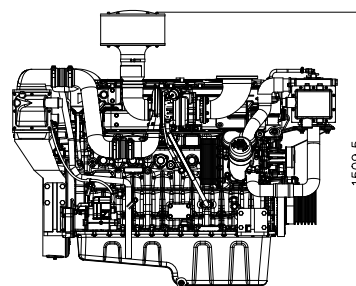
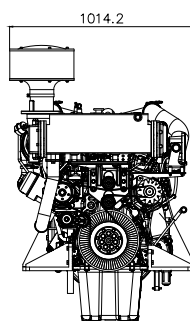
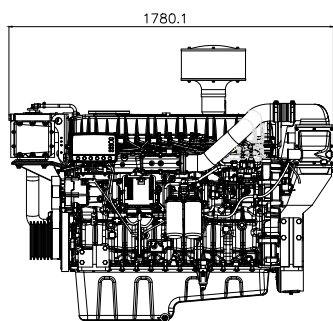
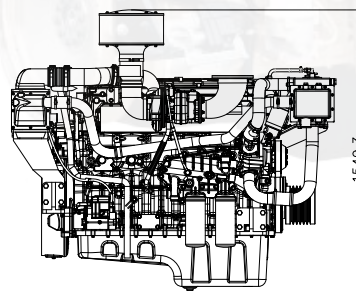
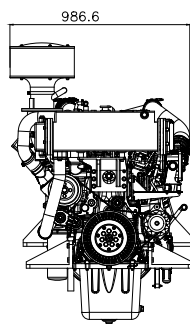
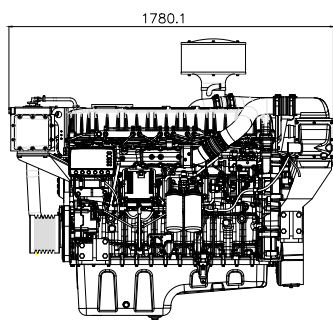

Marine Auxiliary Engine of D Series

Model	Type	Speed (rpm)	Power (HP)	Power (kW)	Disp. (L)
D15C1	V 8	1500	412	307	14.6
D15C2		1800	480	358	
D22C1	V12	1500	605	451	21.9
D22C2		1800	717	535	
D30C1	V16	1500	805	600	29.2
D30C2		1800	959	715	



Note:

1. No reduction in rating for intake air temperature is up to 45°C (318K) and sea water temperature is up to 32 °C (305K) , relative humidity is up to 60 % all data are based on operation to ISO 3046;
2. Operation hours are unlimited per year, at average load is up to 90 %, at full load is up to 80 %;

D SERIES MARINE AUXILIARY ENGINE SPECIFICATION

Engine Model		D15C1	D15C2	D22C1	D22C2	D30C1	D30C2
Engine Type		4 cycle, V-type, direct- injection, water cooled with turbo charger&inter-cooler					
Rating output	kW/rpm	307/1500	358/1800	451/1500	535/1800	600/1500	715/1800
Rating output	PS/rpm	418/1500	486/1800	613/1500	727/1800	816/1500	972/1800
Displacement	cc	14.618		21.927		29.235	
Cylinder number - bore(Φ) x stroke	mm	8- Φ128 x 142		12- Φ128 x 142		16- Φ128 x 142	
Valve clearance at cold - In / Ex	mm	0.3 / 0.4					
Low idling rpm	rpm	800 ±50					
No load max. rpm	rpm	1500	1800	1500	1800	1500	1800
Mean effective pressure	kg/cm2	16.8	16.3	16.5	16.3	16.4	16.3
Mean piston speed	m/sec	7.1	8.52	7.1	8.52	7.1	8.52
Compression ratio		15.5 : 1					
Governor type of injection pump		Electric Governor					

Marine Auxiliary Engine of D Series

D SERIES MARINE AUXILIARY ENGINE SPECIFICATION

Engine Model		D15C1	D15C2	D22C1	D22C2	D30C1	D30C2
Fuel consumption	g/kW.h	204	208	207	209	208	211
	Lit/h	76	90	113	135	150	182
Injection timing (B.T.D.C)	deg	14 °± 1°	14 °± 1°	16°± 1°	16°± 1°	16°± 1°	16°± 1°
Starting system		Electric Starting by starter motor					
Starter motor capacity	V - kW	24-7		24-9		24-11	
Alternator capacity	V - A	24-45					
Battery	V - Ah	24-200		24-400		24-500	
Cooling system		In direct sea water cooling with heat exchanger					
Cooling water capacity - Max. / Min	lit.	89/78		98/87		107/96	
Fresh water pump type		Centrifugal type, driven by belt					
Sea water pump type		Bronze impeller type driven by belt					
Lubricating oil - pan capacity	lit.	Max:27, Min:19		Max:57, Min:41		Max:78, Min:60	
Lubricating oil - pressure	kg/cm2	Full : 3.5, Idle : 1.2					
Direction of revolution - crankshaft		Counter clockwise viewed from stern side					
Engine Size (L x W x H)	mm	1656 x 1230 x 1324		1941 x 1230 x 1325		2340 x 1230 x 1410	
Engine dry weight	kg	1350		1750		2100	

D SERIES MARINE AUXILIARY ENGINE DRAWING

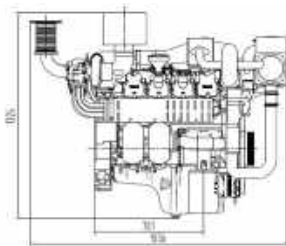
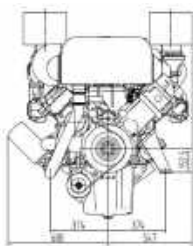

D15C

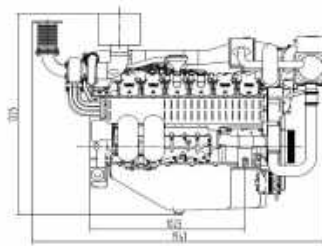

D22C

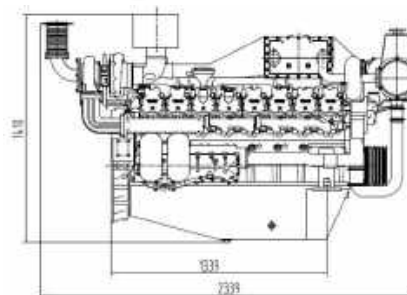

D30C

Marine Auxiliary Engine of CE Series

Model	Type	Speed (rpm)	Power (HP)	Power (kW)	Disp. (L)
CE12C1	L6	1500	426	318	11.8
CE12C2		1800	430	321	
CE13C1	L6	1500	547	408	12.8
CE13C2		1800	548	409	



Note:

1. No reduction in rating for intake air temperature is up to 45°C (318K) and sea water temperature is up to 32 °C (305K) , relative humidity is up to 60 % all data are based on operation to ISO 3046;
2. Operation hours are unlimited per year, at average load is up to 90 %, at full load is up to 80 %;

CE SERIES MARINE AUXILIARY ENGINE SPECIFICATION

Engine Model	CE12C1	CE12C2	CE13C1	CE13C2
Engine Type	4 cycle,direct- injection, water cooled with wet turbo charger & inter-cooler			
	L6 type			
Rating output (kW/rpm)	318/1500	321/1800	408/1500	409/1800
Rating output (HP/rpm)	426/1500	430/1800	547/1500	548/1800
Displacement (L)	11.8		12.8	
Cylinder number - bore(Φ) x stroke (mm)	6- Φ128 x 153		16- Φ130 x 161	
Valve clearance at cold - In / Ex (mm)	0.4 / 0.65			
Low idling (rpm)	650 ± 25			
No load max. (rpm)	1858			
Mean effective pressure (kg/cm ²)	20.2		21.7	
Mean piston speed (m/sec)	7.6	9.2	8.06	9.66
Compression ratio	17 : 1			
Firing order	1-5-3-6-2-4			
Governor type of injection pump	Common rail with ECU			
Fuel consumption (g/kW.h)	197	190	197	190
Fuel consumption (Lit./h)	74	72	95	91
Injection timing (B.T.D.C)	4.5 °± 3°	7.5 °± 3°	4 °± 3.5°	10 °± 1.5°

Marine Auxiliary Engine of CE Series

CE SERIES MARINE AUXILIARY ENGINE SPECIFICATION

Engine Model	CE12C1	CE12C2	CE13C1	CE13C2
Starting system	Electric Starting by starter motor			
Starter motor capacity (V - kW)	24-7.5			
Alternator capacity (V - A)	24-70			
Battery (V - Ah)	24-150			
Cooling system	Indirect sea water cooling with heat exchanger			
Cooling water capacity - Max. / Min (lit.)	45/40			
Fresh water pump type	Centrifugal type, driven by belt			
Sea water pump type	Bronze impeller type driven by belt			
Lubricating oil - pan capacity (lit.)	Max:37, Min:33		Max:41, Min:38	
Lubricating oil - pressure (kg/cm ²)	Full : 5.6; Idle : 1.57			
Direction of revolution - crankshaft	Counter clockwise viewed from stern side			
Engine Size (L x W x H) (mm)	1780 x984 x1549		1780 x1014 x1510	
Engine dry weight (kg)	1265		1170	

CE SERIES MARINE AUXILIARY ENGINE DRAWING

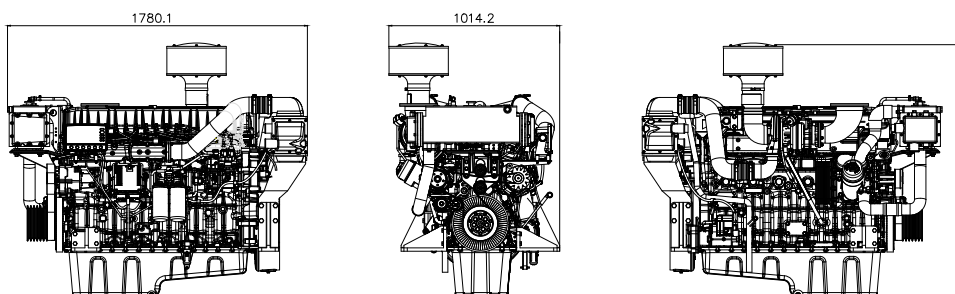
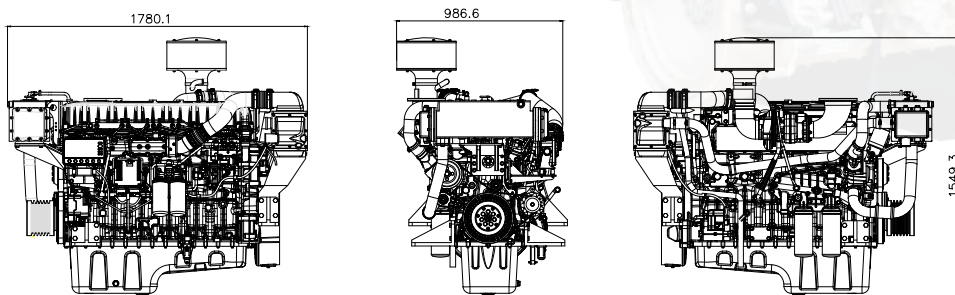





Website



Linked In

Vman

 : Building102-202, Zone E10, Bay Valley II, No.1566
Guoquan Rd(N) Shanghai
200438 China

 : 50 Raffles Place, #34-04 Singapore Land Tower
048623 Singapore

info@vman-engine.com
www.vman-engine.com